

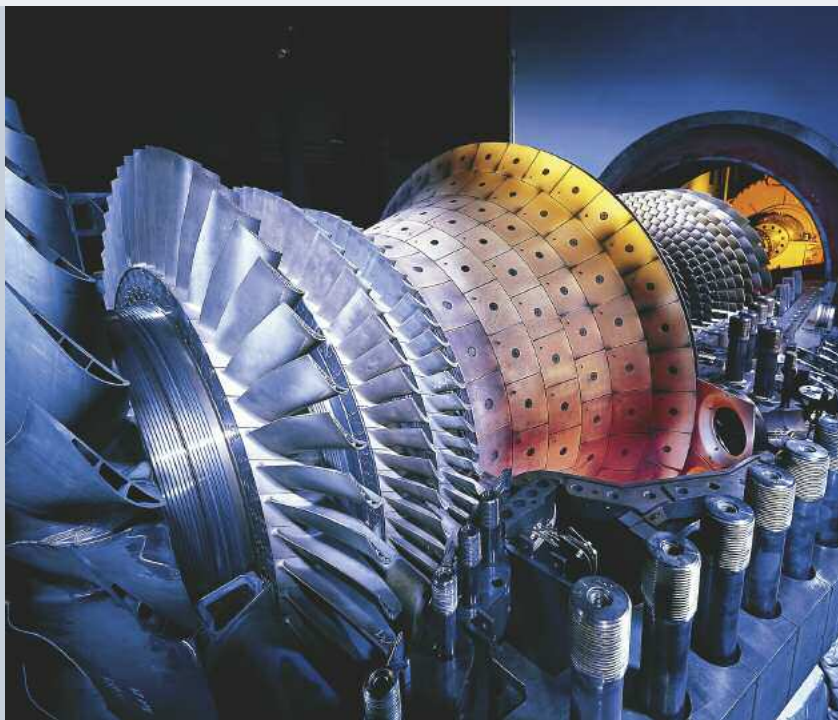

Application of Nano- technologies in the Energy Sector



Hessen – there's no way around us.

Application of Nanotechnologies in the Energy Sector

Imprint

Application of Nanotechnologies in the Energy Sector

Volume 9 of the series Aktionslinie Hessen-
Nanotech of the Hessian Ministry of Economy,
Transport, Urban and Regional Development

Created by:

Dr. Wolfgang Luther
VDI Technologiezentrum GmbH
Zukünftige Technologien Consulting
Graf-Recke-Straße 84
40239 Düsseldorf, Germany

Editorial Staff:

Sebastian Hummel
(Hessian Ministry of Economy, Transport and
Urban and Regional Development)
Dr. Rainer Waldschmidt, Alexander Bracht,
Markus Lämmer
(Hessen Agentur, Hessen-Nanotech)

Publisher:

HA Hessen Agentur GmbH
Abraham-Lincoln-Straße 38-42
65189 Wiesbaden, Germany
Phone +49 (0)611 774-8614
Telefax +49 (0)611 774-8620
www.hessen-agentur.de

The publisher does not take any responsibility for cor-
rectness, preciseness and completeness of the given
information. Opinions and views expressed in this publi-
cation do not necessarily reflect those of the publisher.

© Hessian Ministry of Economy, Transport,
Urban and Regional Development
Kaiser-Friedrich-Ring 75
65185 Wiesbaden, Germany
www.wirtschaft.hessen.de

Reproduction and reprint - even in parts -
subject to prior written approval.

Design: WerbeAtelier Theißen, Lohfelden, Germany
Print: Werbedruck Schreckhase, Spangenberg, Germany
www.hessen-nanotech.de

August 2008

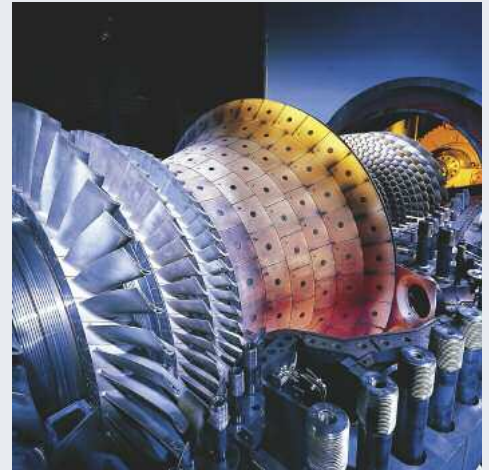

Siemens AG

Illustrations Cover
top: Siemens AG
bottom left: Evonik Degussa GmbH
bottom center: Fraunhofer Institut für solare Energiesysteme
bottom right: BASF

Content

| | | |
|----------|--|----|
| | Preface | 2 |
| | Abstract | 4 |
| 1 | Introduction into Nanotechnologies | 9 |
| 2 | Innovation Potentials in the Energy Sector | 13 |
| 3 | Application Potentials of Nanotechnologies in the Energy Sector | 36 |
| 4 | Practical Examples from Hessen | 54 |
| 5 | Research Programs, Funding and Support Possibilities | 65 |
| 6 | Statements of Associations and Networks in the Energy Sector | 71 |
| 7 | Annex | 78 |

Preface



Dr. Alois Rhiel

Hessian Minister of Economics,
Transport, Urban and Regional
Development

The worldwide energy demand is continuously growing and, according to the forecasts of the International Energy Agency, it is expected to rise by approx. 50 percent until 2030. Currently, over 80 percent of the primary energy demand is covered by fossil fuels. Although their reserves will last for the next decades, they will not be able to cover the worldwide energy consumption in the long run. Nuclear energy covers a part of the global energy demand without climatic effects, according to current assessments, however the supply of nuclear fuels will also run short in the foreseeable future. In view of possible climatic changes due to the increase in the atmospheric CO₂-content as well as the conceivable scarcity of fossil fuels, it becomes clear that future energy supply can only be guaranteed through increased use of renewable energy sources. With energy recovery through renewable sources like sun, wind, water, tides, geothermy or biomass the global energy demand could be met many times over; currently however it is still inefficient and too expensive in many cases to take over significant parts of the energy supply. Due to the usual adaptation reactions on the markets, it is foreseeable that prices for fossil fuels will rise, while significantly reduced prices are expected for renewable energies. Already today, wind, water and sun are economically competitive in some regions. However, to solve energy and climate problems, it is not only necessary to economically utilize renewable alternatives to fossil fuels, but to optimize the whole value added chain of energy, i.e. from development and conversion, transport and storage up to the consumers' utilization. Innovation and increases in efficiency in conjunction with a general reduction of energy consumption are urgently needed in all fields to reach the high aims within the given time since the world population is growing and striving for more prosperity. Nanotechnologies as key

and cross-sectional technologies exhibit the unique potential for decisive technological breakthroughs in the energy sector, thus making substantial contributions to sustainable energy supply. The range of possible nano-applications in the energy sector comprises gradual short and medium-term improvements for a more efficient use of conventional and renewable energy sources as well as completely new long-term approaches for energy recovery and utilization. This NanoEnergy brochure of the Aktionslinie Hessen-Nanotech published by my Ministry is offering information on these topics. The aim is to describe which technical solutions can already be applied today, and for which issues new solution options will be available only in the medium to long run. With this, we want to trigger off innovation processes urgently required in Hessian companies and science.

Dr. Alois Rhiel
Hessian Minister of Economics, Transport,
Urban and Regional Development

Key to Sustainable Energy Supply



Prof. Dr. Jürgen Schmid

Chairman of Institut für Solare
Energieversorgungstechnik
(ISET), Kassel

High demands are placed on a strategy for the reorganization of the current energy supply structure: The drastic reduction of global CO₂-emissions with contemporaneously high supply reliability requires strategic changes in the design of future energy systems. Apart from the enhancement of energy efficiency, mainly the quick implementation of low-emission technologies has to be advanced. Renewable energies have a long-term potential to take over the entire global energy supply. However, during a transition period, conventional fossil fuels will have to be utilized and, probably, technologies for the separation and safe final storage of CO₂ in suitable deposits. In this case, the transformation process has to allow utmost flexibility and economic efficiency for the application of individual energy technologies. Utmost efficiency of supply systems will be achieved, if preferably all fossil and biogenous energy sources are used for the coupled generation of electric current and heat. This also includes the possibility of highly efficient exploitation of coal through coal gasification. The feeding into the natural gas grid anyway requires the CO₂ separation from biogas or the conversion of synthesis gas into methane and may thus be a first step towards decarbonization. The almost complete separation of carbon both from synthesis gas and methane and the provision of pure hydrogen are possible in a later stage without difficulty. The utilization of nanotechnologies in the most important fields of energy supply such as building, transport and traffic, portable resp. off-grid power applications may contribute decisively to the solution of these problems. Due to the existing research and development capacities in universities and extra-faculty facilities, above all in industry, the state of Hessen is already well-positioned in nanotechnologies and the adjacent fields of material and surface technologies, microsystems technologies and optical

technologies. The future challenge is the integration of the promising nanotechnological approaches into technical innovations for the development of a sustainable energy supply up to the commercial implementation, and their realization as a contribution to cost reduction in renewable energies to increase efficiency in generation and consumption. To enhance competitiveness and innovative strength of Hessian enterprises, intensive cooperation with Hessian universities and research facilities may provide essential impulses, in particular by combining the fields of materials research and energy research.

Against the background of the potential of nanotechnologies in the energy sector, the previous research and development activities altogether seem to have room for improvement. Therefore, we actively support the very welcome initiative of the Aktionslinie Hessen-Nanotech of the Hessian Ministry of Economy to spotlight the issue of NanoEnergy with projects, events and this brochure.

A handwritten signature in blue ink, appearing to read 'J. Schmid'.

Prof. Dr. Jürgen Schmid
Institute for Solar Energy Technology
(ISET, Germany)

Abstract

Nanotechnologies provide the potential to enhance energy efficiency across all branches of industry and to economically leverage renewable energy production through new technological solutions and optimized production technologies. In the long run, essential contributions to sustainable energy supply

and the global climate protection policy will be achieved. Here, nanotechnological innovations are brought to bear on each part of the value-added chain in the energy sector.

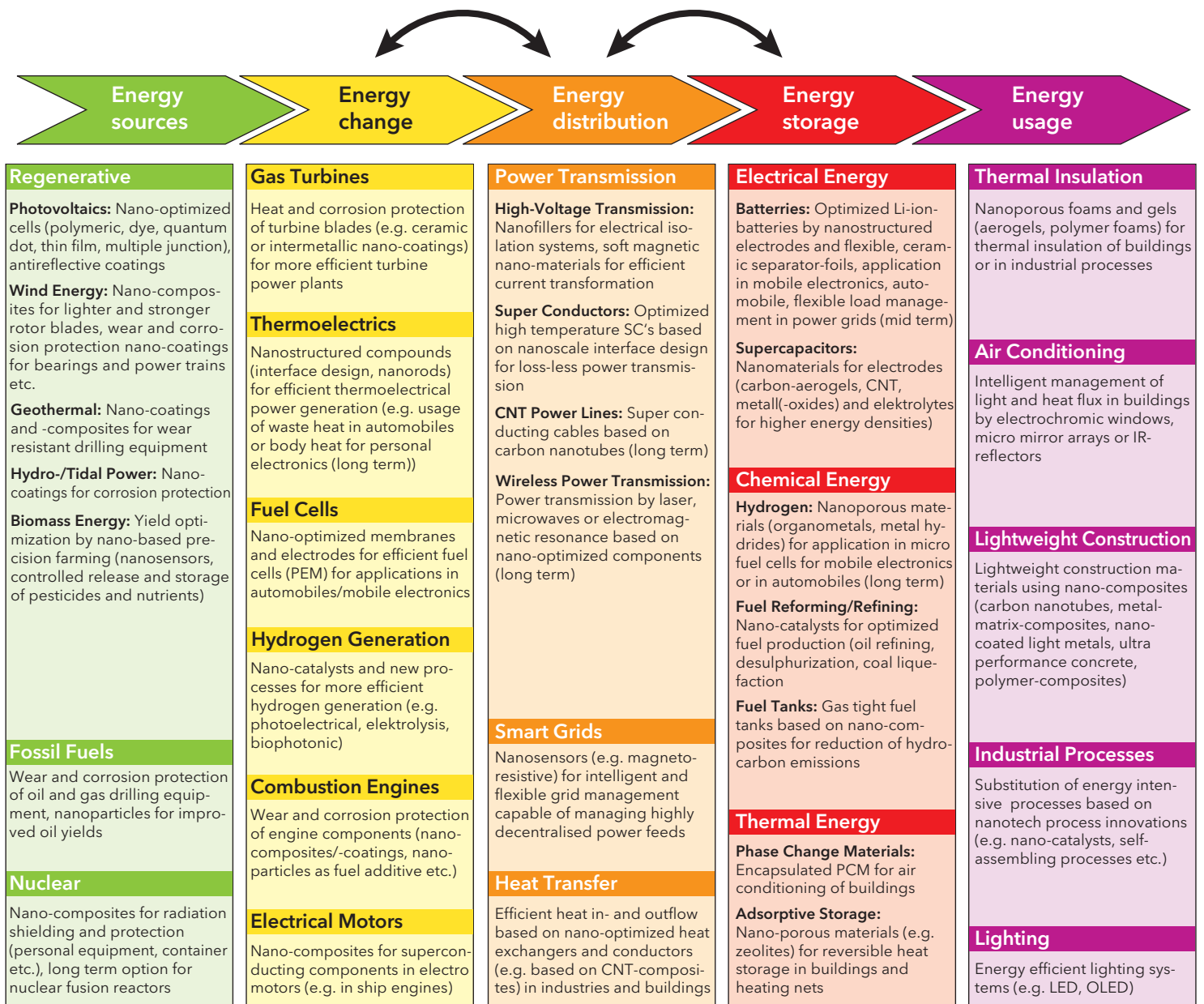

Examples for potential applications of nanotechnology along the value-added chain in the energy sector (source: VDI TZ GmbH)

Development of Primary Energy Sources

Nanotechnologies provide essential improvement potentials for the development of both conventional energy sources (fossil and nuclear fuels) and renewable energy sources like geothermal energy, sun, wind, water, tides or biomass. Nano-coated, wear-resistant drill probes, for example, allow the optimization of lifespan and efficiency of systems for the development of oil and natural gas deposits or geothermal energy and thus the saving of costs. Further examples are high-duty nanomaterials for lighter and more rugged rotor blades of wind and tide-power plants as well as wear and corrosion protection layers for mechanically stressed components (bearings, gear boxes, etc.). Nanotechnologies will play a decisive role in particular in the intensified use of solar energy through photovoltaic systems. In case of conventional crystalline silicon solar cells, for instance, increases in efficiency are achievable by antireflection layers for higher light yield. First and foremost, however, it will be the further development of alternative cell types, such as thin-layer solar cells (among others of silicon or other material systems like copper/indium/selenium), dye solar cells or polymer solar cells, which will predominantly profit from nanotechnologies. Polymer solar cells are said to have high potential especially regarding the supply of portable electronic devices, due to the reasonably-priced materials and production methods as well as the flexible design.

Medium-term development targets are an efficiency of approx. 10% and a lifespan of several years. Here, for example, nanotechnologies could contribute to the optimization of the layer design and the morphology of organic semiconductor mixtures in component structures. In the long run, the utilization of nanostructures, like quantum dots and wires, could allow for solar cell efficiencies of over 60%.

Energy Conversion

The conversion of primary energy sources into electricity, heat and kinetic energy requires utmost efficiency. Efficiency increases, especially in fossil-fired gas and steam power plants, could help avoid considerable amounts of carbon dioxide emissions. Higher power plant efficiencies, however, require higher operating temperatures and thus heat-resistant turbine materials. Improvements are possible, for example, through nano-scale heat and corrosion protection layers for turbine blades in power plants or aircraft engines to enhance the efficiency through increased operating temperatures or the application of lightweight construction materials (e.g. titanium aluminides). Nano-optimized membranes can extend the scope of possibilities for separation and climate-neutral storage of carbon dioxide for power generation in coal-fired power plants, in order to render this important method of power generation environmentally friendlier in the long run. The energy yield from the conversion of chemical energy through fuel cells can be stepped up by nano-structured electrodes, catalysts and membranes, which results in economic application possibilities in automobiles, buildings and the operation of mobile electronics. Thermoelectric energy conversion seems to be comparably promising. Nano-structured semiconductors with optimized boundary layer design contribute to increases in efficiency that could pave the way for a broad application in the utilization of waste heat, for example in automobiles, or even of human body heat for portable electronics in textiles.



(Source: Siemens AG)

Low-loss Power Transmission and Smart Grids

Regarding the reduction of energy losses in current transmission, hope exists that the extraordinary electric conductivity of nanomaterials like carbon nanotubes can be utilized for application in electric cables and power lines. Furthermore, there are nanotechnological approaches for the optimization of superconductive materials for lossless current conduction. In the long run, options are given for wireless energy transport, e.g. through laser, microwaves or electromagnetic resonance. Future power distribution will require power systems providing dynamic load and failure management, demand-driven energy supply with flexible price mechanisms as well as the possibility of feeding through a number of decentralized renewable energy sources. Nanotechnologies could contribute decisively to the realization of this vision, inter alia, through nano-sensory devices and power-electronical components able to cope with the extremely complex control and monitoring of such grids.

Energy Storage

The utilization of nanotechnologies for the enhancement of electrical energy stores like batteries and super-capacitors turns out to be downright promising. Due to the high cell voltage and the outstanding energy and power density, the lithium-ion-technology is regarded as the most promising variant of electrical energy storage. Nanotechnologies can improve capacity and safety of lithium-ion-batteries decisively, as for example through new ceramic, heat-resistant and still flexible separators and high-performance electrode materials. The company Evonik pushes the commercialization of such systems for the application in hybrid and electric vehicles as well as for stationary energy storage.

In the long run, even hydrogen seems to be a promising energy store for environmentally-friendly energy supply. Apart from necessary infrastructural adjustments, the efficient storage of hydrogen is regarded as one of the critical factors of success on the way to a possible hydrogen management.

Current materials for chemical hydrogen storage do not meet the demands of the automotive industry which requires a H₂-storage capacity of up to ten weight percent.

Nanostructured heat protection layers for gas turbines



High temperature superconductors for motors and generators in ships



Nano-optimized fuel cells for automobiles and transport vehicles

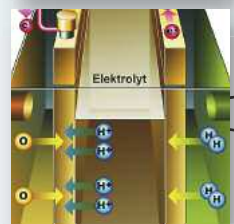

Nanomembranes for separation of carbon dioxide in CCS (Carbon Capture and Storage) power plants



Nanocrystalline magnetic materials for efficient components in current transformation and supply (e.g. transformers, electric meters etc.)



Various nanomaterials, inter alia based on nanoporous metalorganic compounds, provide development potentials which seem to be economically realizable at least with regard to the operation of fuel cells in portable electronic devices. Another important field is thermal energy storage. The energy demand in buildings, for example, may be significantly reduced by using phase change materials such as latent heat stores. Interesting, from an

economic point of view, are also adsorption stores based on nanoporous materials like zeolites, which could be applied as heat stores in district heating grids or in industry. The adsorption of water in zeolite allows the reversible storage and release of heat (see practical example Viessmann, p. 60).

Scenario with examples for future application possibilities of nanotechnologies in the energy sector
(Design: VDI TZ GmbH; Photo credits: Siemens, BASF, Evonik, Bayer, FHG-ISE, Rewitec, GKSS, Magnetec, FH Wiesbaden)

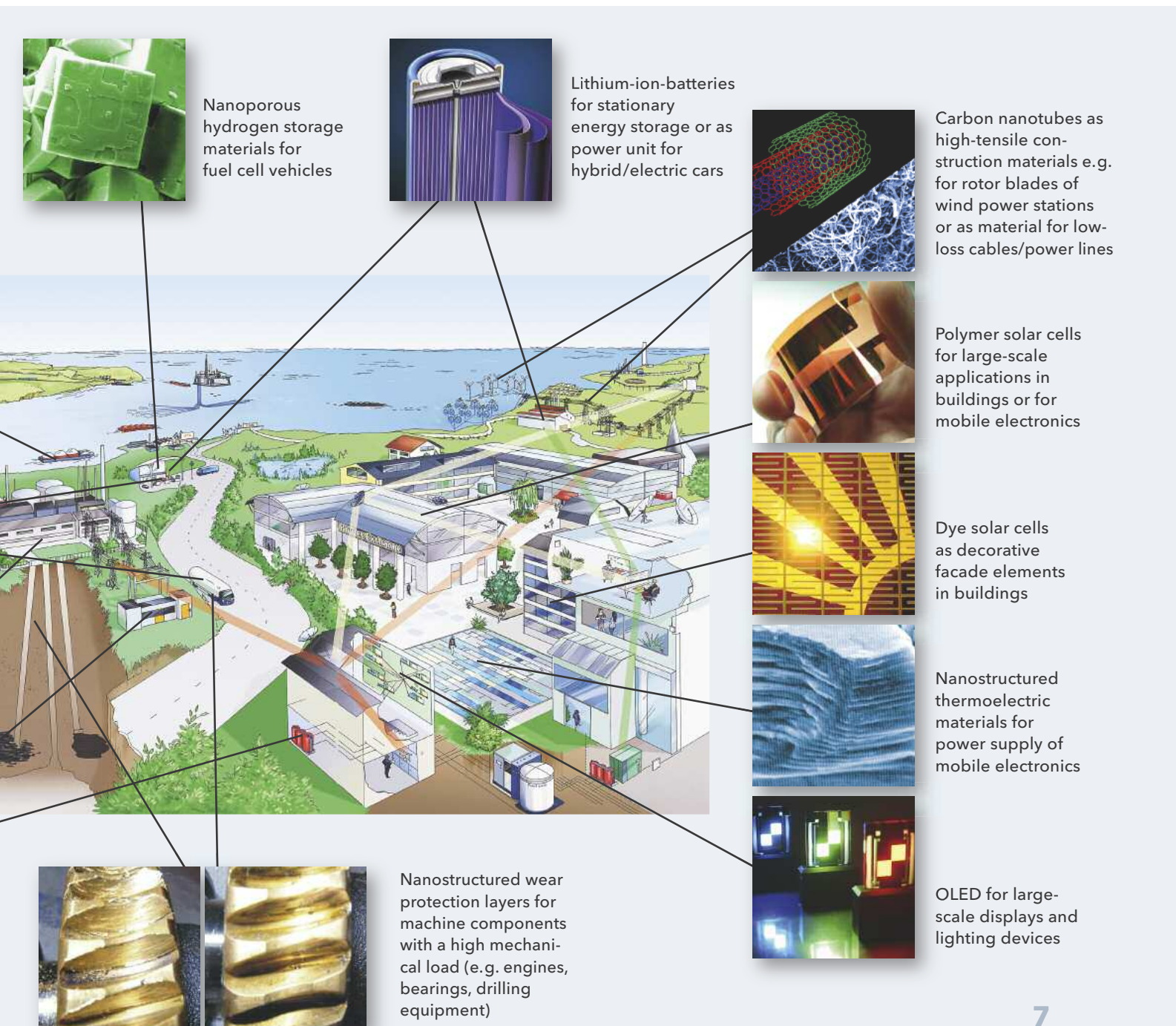

Energy Use

To achieve sustainable energy supply, and parallel to the optimized development of available energy sources, it is necessary to improve the efficiency of energy use and to avoid unnecessary energy consumption. This applies to all branches of industry and private households. Nanotechnologies provide a multitude of approaches to energy saving. Examples are the reduction of fuel consumption in automobiles through lightweight construction materials on the basis of nanocomposites, the optimization in fuel combustion through wear-resistant, lighter engine components and nanoparticulate fuel additives or even nanoparticles for optimized tires with low rolling resistance (cf. brochure Automotive Nanotechnologies). Considerable energy savings are

realizable through tribological layers for mechanical components in plants and machines, as commercially marketed by REWITEC from Lahnau (cf. practical example on page 61). Building technology also provides great potentials for energy savings, which could be tapped, for example, by nanoporous thermal insulation material suitably applicable in the energetic rehabilitation of old buildings. In general, the control of light and heat flux by nanotechnological components, as for example switchable glasses, is a promising approach to reducing energy consumption in buildings (cf. brochure Uses for Nanotechnologies in Architecture and Civil Engineering).

Conclusion

In view of a globally increasing energy demand, threatening climatic changes due to continuously increasing carbon dioxide emissions, as well as the foreseeable scarcity of fossil fuels, the development and provision of sustainable methods for power generation belong to the most urgent challenges of mankind. Massive effort at political and economical level is required to basically modernize the existing energy system. Growing efficiency and new methods through nanotechnological know-how may play a key role for the required innovation in the energy sector. Nanotechnological components provide potentials for the more efficient utilization of energy reserves and the more economical development of renewables. This brochure provides a number of examples for possible applications and developments in which Hessian enterprises and research facilities are actively involved.

When implementing nanotechnological innovations in the energy sector, the macroeconomic and social context must not be lost sight of. The design of a future energy system requires long-term investments in research activities based on realistic potential assessments and the careful adaptation of the individual supply chain components. In case of renewable energy production by wind or solar energy, for example, it has to be considered that power generation occurs discontinuously and energy stores have to be provided as buffers to balance the fluctuating demand.

When replacing fossil fuels, not only their function as energy source, but also as energy store has to be taken into account, for instance in the automotive sector. Here, alternatives must be found for the long-term storage of energy and its availability at short notice and in an efficient infrastructure. The move into hydrogen economy and the increased utilization of biofuels are discussed as solutions for the future, which, however, require considerable investments and technological leaps, inter alia on the basis of nanotechnologies. Further challenges of the energy sector are the optimization and integration of mobile energy supply systems for the operation of wireless electronic devices, tools and sensors, which have become a key factor in modern industrial society.

To enable the immediate practical implementation of nanotechnological innovations in such a broad field like the energy sector, an interbranch and interdisciplinary dialog with all players involved will be required. This brochure wants to contribute to building a bridge and providing generally understandable information for coordinated and target-oriented acting in politics, economy and society.

1 Introduction into Nanotechnologies

Nanotechnologies are worldwide regarded as key technologies for innovations and technological progress in almost all branches of economy. Nanotechnologies refer to the target-oriented technical utilization of objects and structures in a size in the range of 1 and 100 nm. They are less seen as basic technologies in the classic sense with a clear and dis-

tinct definition, than they describe interdisciplinary and cross-sector research approaches, for example in electronics, optics, biotechnology or new materials, using effects and phenomena which are only found in the nano-cosmos.

1.1 Definition of Nanotechnologies

Up to now, there is no internationally accepted definition of nanotechnologies. First approaches are currently being worked out by the International Standardization Organization (ISO) (cf. brochure Nano-Standardization). The topical area of nanotechnologies, however, does not reveal itself through formal definitions, but through the description of basic principles and research approaches playing a decisive role in this connection. On the one hand, in nanotechnologies, engineering with elementary units of biological and inorganic nature, i.e. atoms and molecules, is applied as if working with a lego-kit ("bottom-up strategy"). On the other hand, even structures measuring only one thousandth of the diameter of one hair can be created by means of size reduction ("top-down strategy"). This problem is comparable to the challenge of writing the whole road network of Germany, true to scale, on a fingernail- and faultlessly, of course. Partially, nanotechno-

logical processes as such are not basically new, but often represent further developments of proven production and analysis techniques. Nano-effects had already been used in the Middle Ages, for instance, for the red staining of church windows by finely distributed gold colloids or for the hardening of Damascus steel of sword blades by carbon nanotubes, without being aware of the physicochemical principles. Thus, the essence of nanotechnologies is the controlled utilization of nano-scale structures, the understanding of the principles effective at molecular level and the technological improvement of materials and components.

Nanotechnologies describe the creation, analysis and application of structures, molecular materials, inner interfaces and surfaces with at least one critical dimension or with manufacturing tolerances (typically) below 100 nanometers. The decisive factor is that new functionalities and properties resulting from the nanoscalability of system components are used for the improvement of existing products or the development of new products and application options. Such new effects and possibilities are predominantly based on the ratio of surface-to-volume atoms and on the quantum-mechanical behavior of the elements of the material.

1.2 Nanoeffects as a Basis for Product Innovations

In contrast to coarser-structured materials, nanomaterials dispose of drastically modified properties concerning physical, chemical and biological features. Physical material properties of a solid, such as electric conductivity, magnetism, fluorescence, hardness or strength change fundamentally in accordance to the number and arrangement of the interacting atoms, ions and molecules. In contrast to macroscopic solids, electrons in a nanocluster can only adopt certain "quantized" energy states influenced by the number of interacting atoms.

This results in characteristic fluorescence properties which vary strongly with the size of the cluster. A cadmium telluride particle of 2 nm, for example fluoresces green light, while a particle of 5 nm fluoresces red light. Such quantum dots principally allow a significant enhancement of the quantum yield of solar cells and thus of their conversion efficiency. Even chemical material properties depend much on the arrangement and structuring of atoms and molecules. Nanostructuring usually achieves significantly higher chemical reactivity, since materials broken down to nanoscale substructures show a strongly increased ratio of reactive surface atoms to inert particles in a solid. In a particle with a diameter of 20 nm, for example approx. 10% of the atoms are on the surface, while in a particle of 1 nm the ratio of reactive surface atoms amounts to already 99%. In

biology, nanomaterials play a decisive role, too, since nearly all biological processes are controlled by nanoscale structural components such as nucleic acid, proteins etc. The structuring of complex biological systems, like cells and organs, occurs according to the self-organization principle, where individual molecules are assembled to larger units on the basis of chemical interactions and molecular recognition mechanisms. In the history of evolution, nature succeeded in realizing extremely complex reaction mechanisms, such as photosynthesis, due to the highly efficient interaction of such "molecular machines". This is the basis for life on earth and also for today's energy supply, which is mainly based on the utilization of fossil energy supplies generated by photosynthesis during the history of earth.

The smaller the particle, the larger the portion of particles present on the reactive surface of the particle (blue) in contrast to the more inert center of the particle (red). With particle sizes between 1 nm and 20 nm, the ratio of surface particles to total number of particles varies considerably.

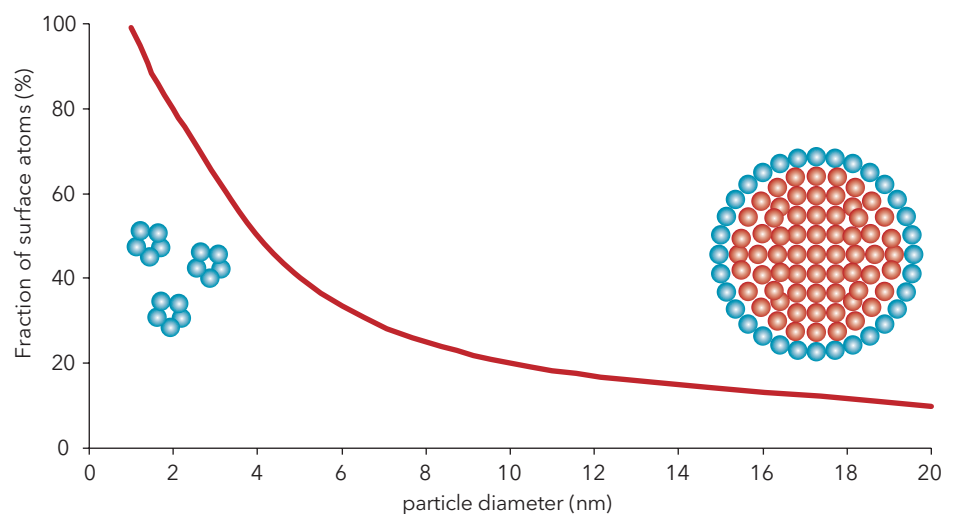

Although the total energy yield of photosynthesis is relatively low (despite a high quantum yield in the reactive center of the photosynthesis complex of approx. 97 %, altogether less than 1 % of the radiated light energy is being transformed into chemical energy), this may serve as a paradigm for future technical energy conversion systems, for example for Organic Photovoltaics. This applies in particular to the production through self-organizing processes from elementary basic modules as well as to high function stability and regenerability.

Thus, nanostructuring provides new possibilities for intelligent material design, with the possibility of combining the desired material properties and adjusting them to the respective technical application purpose.

For the energy sector, inter alia, the examples listed in the following overview are of interest.

Chemical

- More efficient catalysts in fuel cells or for the chemical conversion of fuels through extended surfaces and specific catalyst design.
- More powerful batteries, accumulators and supercapacitors through higher specific electrode surfaces.
- Optimized membranes with higher temperature and corrosion resistance for application in polymer electrolyte fuel cells or separators in lithium-ion-batteries.
- Nanoporous materials for the storage of hydrogen, e.g. metal hydrides or metalorganic compounds.

Mechanical

- Improved strength of construction materials for rotor blades of wind power plants.
- Wear-resistant nanolayers for drill probes, gear boxes and engine components.
- Optimized separability of gas membranes for the separation and deposition of carbon dioxide from flue gases of coal-fired power plants.
- Gas-tight polymer nanocomposites for the reduction of hydrocarbon emissions from vehicle tanks.

Optical

- Optimized light absorption properties of solar cells through quantum dots and nanolayers in stack cells.
- Anti-reflection properties for solar cells to increase energy yield of solar cells.
- Luminescent polymers for the production of energy-efficient organic light diodes.

Electronic

- Optimized electron conductivity through carbon nanotubes and nano-structured superconductors.
- Electric insulators through nano-structured fillers in components of high-voltage power lines.
- Enhanced thermoelectrics for more efficient power generation from heat through nano-structured layer systems.

Thermal

- Nano-structured heat protection layers for turbine blades in gas and aircraft turbines.
- Improved heat conductivity of carbon nanotubes for optimized heat exchangers.
- Optimized heat stores based on nanoporous materials (zeolites) or microencapsulated phase-change storage.
- Nanofoams as super-insulation systems in building insulation which are capable of efficiently minimizing the convective heat transport even at small thickness of the insulation layer, due to the nanoporous structure.

1.3 International Status Quo

In 2006, the investments in the field of nanotechnologies amounted to approx. 12.4 bn \$ with public and private investments of approx. 6.4 bn \$ resp. 6 bn \$ being more or less balanced. The private investments are attributable to company investments with 5.3 bn \$ and to Venture Capital Investment with approx. 0.7 bn \$ (Source: Lux Research 2007). With regard to private investments, the USA is in the lead, closely followed by Asia and clearly ahead of Europe. Regarding public investments however, Europe (European Commission and member countries) with approx. 1.7 bn \$, the USA (at federal and state level) with approx. 1.9 bn \$ and Japan with approx. 975 m \$ belong to the three leading regions in nanotechnologies worldwide. Other countries, in particular in Southeast Asia, China and India increase their commitment considerably and close up quickly. This enormous public commitment is driven by the high expectations regarding the overall economic benefit in the form of turnovers and employment directly related to nanotechnological developments.

In international comparison, Germany is well positioned in nanotechnologies. With regard to public R&D expenses and patent applications in nanotechnologies, Germany ranks third worldwide. Concerning nanoscientific publications, Germany was also ranking third in the last years, but meanwhile it has been displaced in rank by China and is now fourth. The strengths of Germany comprise the well-developed R&D infrastructure and the advanced level of research and development in various disciplines of nanotechnologies, as in nanooptics, nanomaterials, nanoanalytics and nanobiotechnology. With currently 700 enterprises involved in development, application and sales of nanotechnological products, there is an industrial basis for the utilization of the research results. With more than 100 enterprises, the state of Hessen belongs to the strongest regions with regard to the economic realization of nanotechnology in Germany. In many branches of economy, nanotechnological know-how already contributes decisively to economic competitiveness - in particular in the mass markets of electronics, chemistry and optical Industry.

In the medium to long term, nanotechnologies will also have considerable commercial influence in the fields of car manufacturing, Life Science and traditional branches of industry like construction engineering and textile industry. Although the enormous economic importance of nanotechnologies as key and interdisciplinary technologies is undisputed, the economic potential of nanotechnologies is hardly quantifiable. This is due to the fact that nanotechnology as an "enabling technology" sets in at a relatively early stage of the value added chain, i.e. at the optimization of components/intermediate products, e.g. through nanoscale coatings or nanostructured materials. Usually, these components account only for a small part of the finished end products (consumer and investment goods). Frequently, the market value of nanotechnological components in the added value of the end product cannot be exactly determined. However, without the application of nanotechnological procedures and components, products of many industrial branches would not be competitive (e.g. hard disc storage units, computer chips, ultra-precision optics, etc.).

2 Innovation Potentials in the Energy Sector

Energy “powers” our life; it provides our living space and working environment with pleasant temperatures and lightness, it feeds production plants, urban infrastructure as well as the multitude of our electronic assistants in everyday life and enables almost unlimited mobility around the globe. The worldwide energy demand increases continuously and, according to forecasts of the International Energy Agency, it will rise from currently approx. 12,000 MTOE (million tons oil equivalents) up to more than 18,000 MTOE until 2030 (approx. 750 exajoule = 750.000.000.000.000.000 Joule). The major driver for this sharp increase in energy consumption, and thus also in the worldwide carbon dioxide emission, is in particular the backlog demand of upcoming economies like China and India, which more and more adapt their energy consumption to that of the industrial nations and mostly use fossil fuels. The largest share in global energy consumption is attributable to the industrial sector, followed by transport and traffic, households and other business enterprises (services, trade etc.). However, there are big regional differences regarding energy consumption and the development in the individual sectors. In industrial nations like Germany, for instance, transport holds the top position in energy consumption

showing also the highest growth rates, while the energy consumption in the industrial sector declined in the last years.

At a global level, however, an increase in all sectors is forecasted, with the highest growth rates being expected in Non-OECD countries like China and India. It is obvious that for the long-term coverage of this increasing energy demand, a radical change in the energy sector is required, which means a development away from previously dominating fossil fuels towards the enhanced utilization of renewable energy sources. The threatening climatic change caused by rising carbon dioxide emission and the foreseeable scarcity of fossil fuels leaves no other choice than to further push the urgently needed innovations in the energy sector. This applies both to the enhanced development of renewable energy sources and to the entire value-added chain including energy recovery from primary energy sources, conversion, storage, distribution as well as the use of energy.

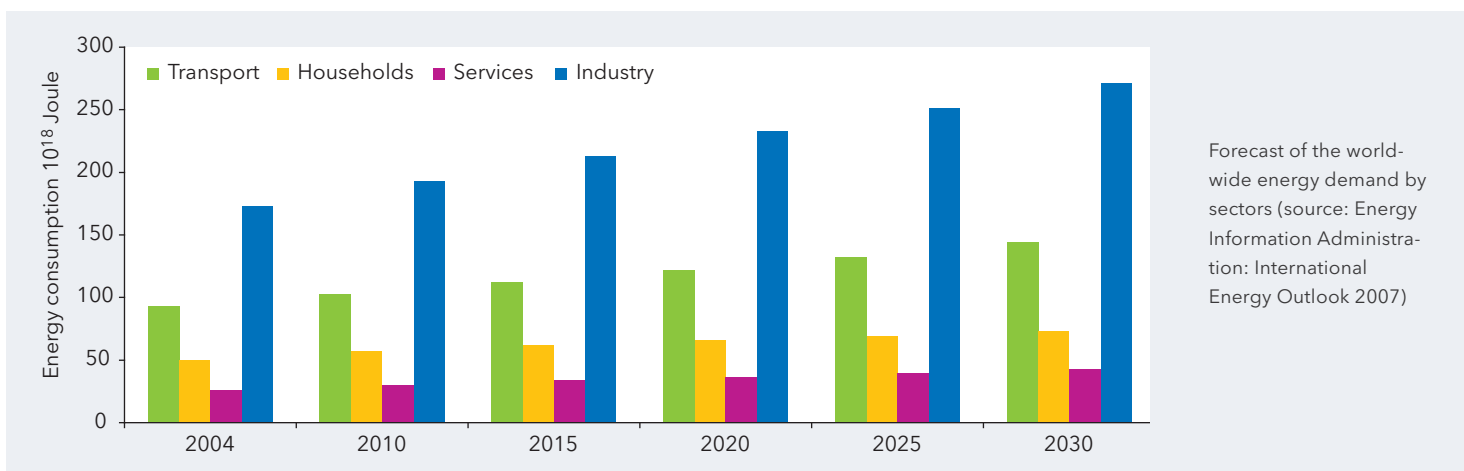

2.1 Potentials of Primary Energy Sources

With about 80%, the fossil fuels coal, crude oil and natural gas cover the main part of the current global energy demand. Current scenarios for the development of the future energy demand go on the assumption that the share of fossil fuels in the worldwide supply will remain nearly unchanged until 2030. This trend can only be countered by massive global effort and investments in the field of renewable energies and by energy saving measures. The European Union sees itself in a pioneer role and has set the ambitious target to achieve a binding share of renewables in the overall EU-energy consumption of 20%, a reduction of the EU-wide greenhouse gases by 20% and an increase in energy efficiency by 20% by 2020.

Currently the global share in renewable energies amounts to about 15%, with energy recovery from biomass being clearly in the lead. It is followed by water power and geothermal energy, while wind and solar power together account for a share of below one percent. The following figure represents the global state of the year 2004 in relation to the total primary energy supply, i.e. current and heat supplies as well as fuels.

Share of different energy sources in the global primary energy supply in the year 2004 (source: Energy Information Administration, Annual Energy Review 2006)

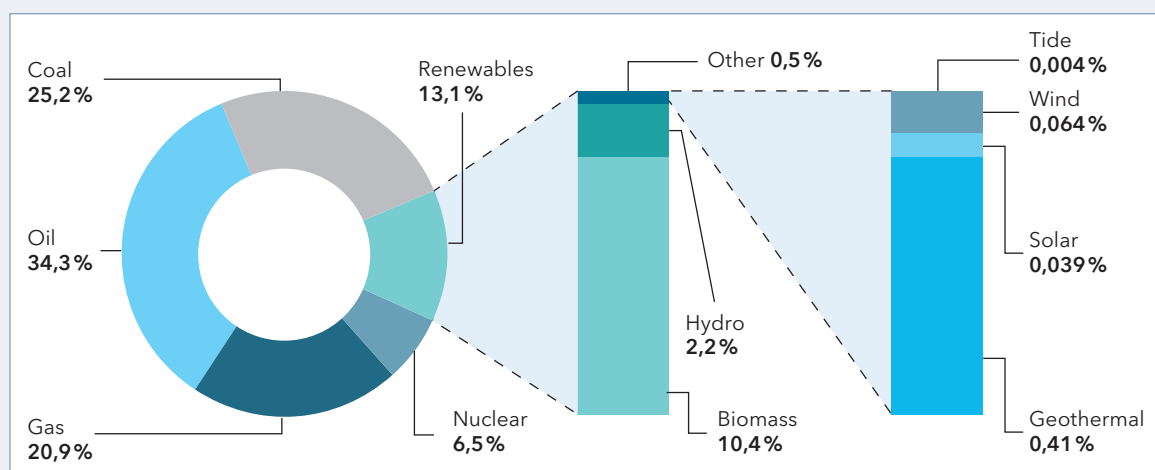

There are great regional differences regarding to the utilization of renewables. In Germany, the share of renewable energy sources in the total energy consumption is currently at approx. 9% and thus below the global average, a fact mainly due to the low utilization of biomass for energy supply in comparison to less industrialized nations. However, there had been a sharp upward trend in the utilization of renewable energy sources in Germany during the last years, especially in the field of electric power supply. Due to a very dynamic development in the wind energy sector, its share in the total energy supply in Germany amounts already to more than 5%. Sharp growth rates were also achieved in photovoltaics, although with a total share of 0.5% in the

power demand they are hardly noticeable in the total amount. Thus, the ambitious objective of the Federal Government, to cover half of the total power demand in Germany by renewables until 2050, is still a distant prospect. Such objectives will only be realizable through new approaches and technological breakthroughs, which enable a considerable improvement in efficiency in the supply of renewables and the development of significant efficiency potentials throughout the whole value-added chain of the energy sector.

The total potential of fossil fuels available on earth is assessed at approx. 5.500 MTOE, with 60% attributable to coal, approx. 30% to natural gas and approx. 10% to crude oil. In principle, this amount of energy suffices to meet the global energy demand for some centuries. It has to be considered however that, a large part of the global crude oil and natural gas resources cannot be efficiently utilized with conventional methods. The statistical range of already developed resources is assessed at approx.

40 to 60 years for crude oil, natural gas and uranium, and at approx. 200 years for coal. These figures vary continuously according to the development of the worldwide consumption and progresses in exploration and production technologies. With regard to crude oil, however it will be necessary to revert, to an increasing extent, to non-conventional sources like heavy oil, oil sand or oil shale, the development of which entails high costs and environmental impacts.

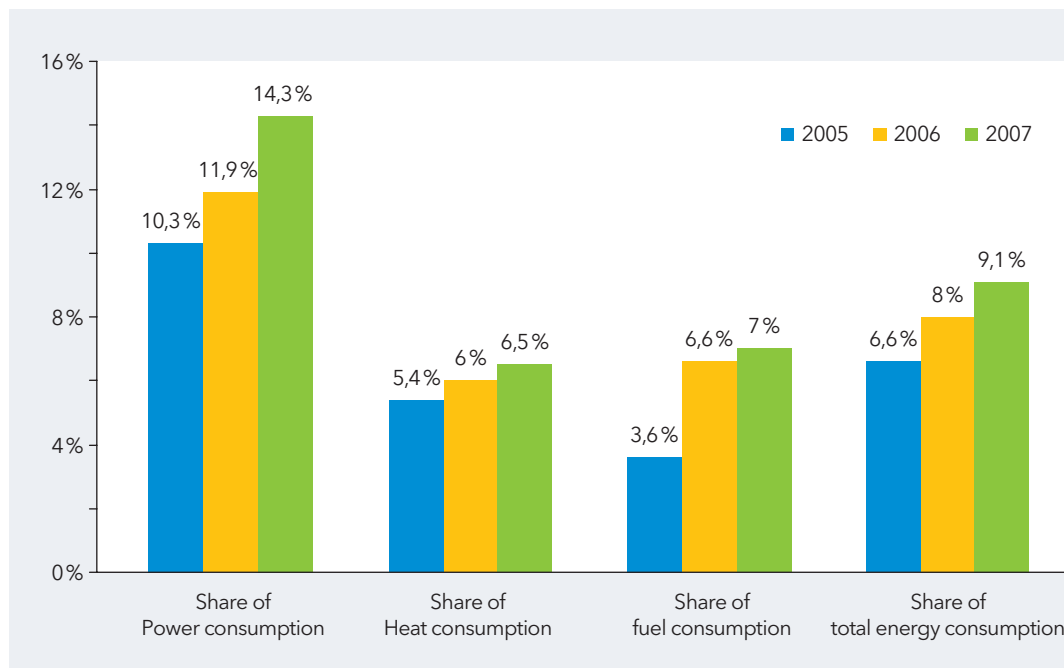

Market shares of renewables in Germany 2005-2007 (source: German Federal Association of Renewable Energies 2008)

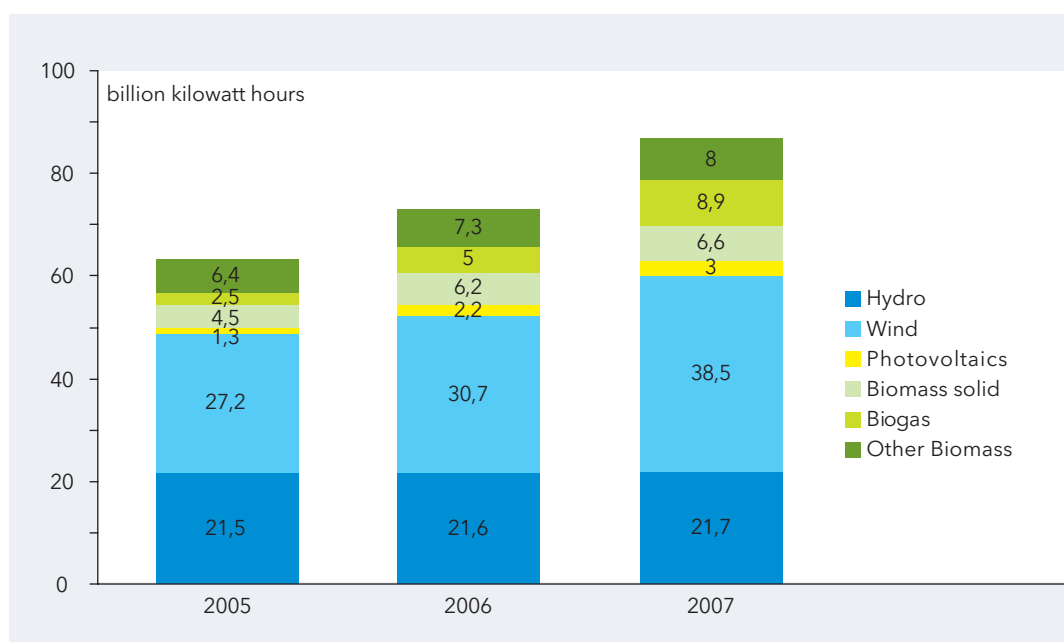

Energy supply through renewable energy sources in Germany 2005-2007 (source: German Federal Association of Renewable Energies 2008)

Range of conventional fuels in years (source: German Federal Institute for Geosciences and Natural Resources, BGR, 2007 www.bgr.bund.de)

reserves: assured deposits which can be exploited economically with existing technology

resources: ascertained deposits, which can not be exploited economically with existing technology resp. presumed not localized deposits

conventional: economically exploitable with current extraction technology

unconventional: need for new extraction technologies for economical exploitation

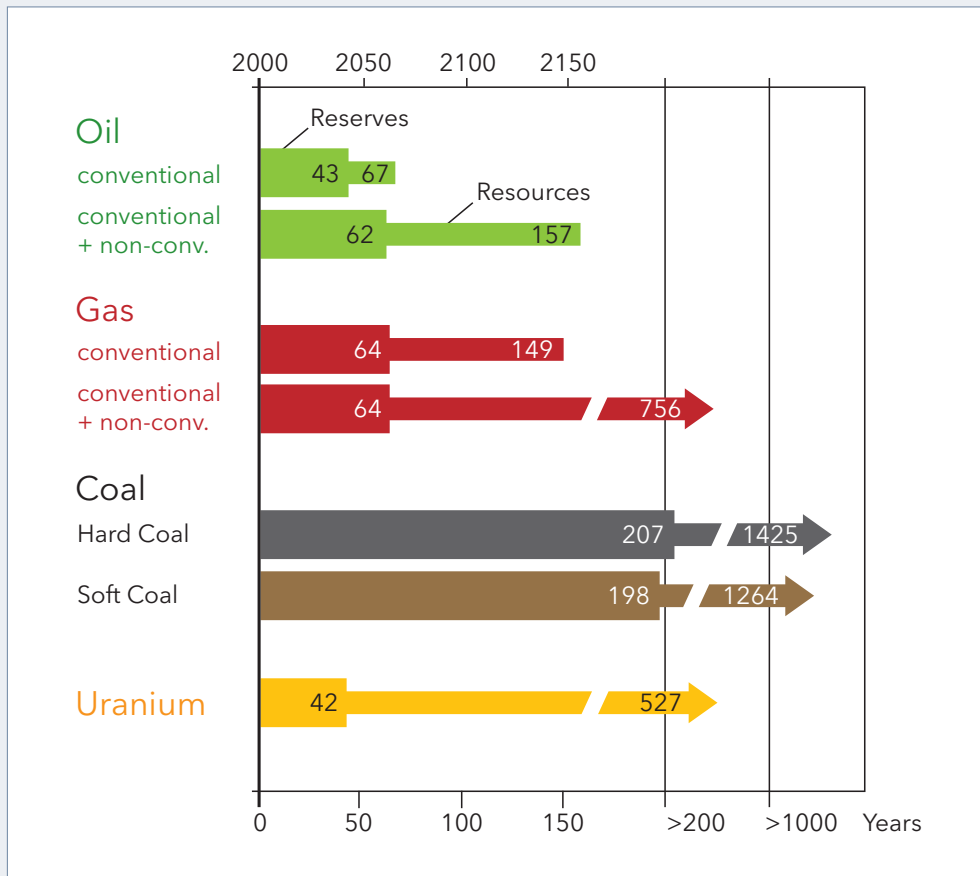

The potential of renewable energy sources is unequally higher. Especially through direct utilization of the sun's radiation energy the global energy demand could be met many times over. Wind and tidal energies also provide considerable potentials. From today's view, however the technically and economically usable part of it is negligible, above all due the low energy density and the limited number of economically usable locations. The energy yield from the incidence of solar radiation on the earth's

surface in Central Europe, for example, is limited to a maximum of approx. 1000 Watt per square meter. Further constraints on the utilization of renewable energies are the inconsistent energy yield in dependence of environmental influences, low efficiencies in energy conversion as well as cost-intensive production methods and materials.

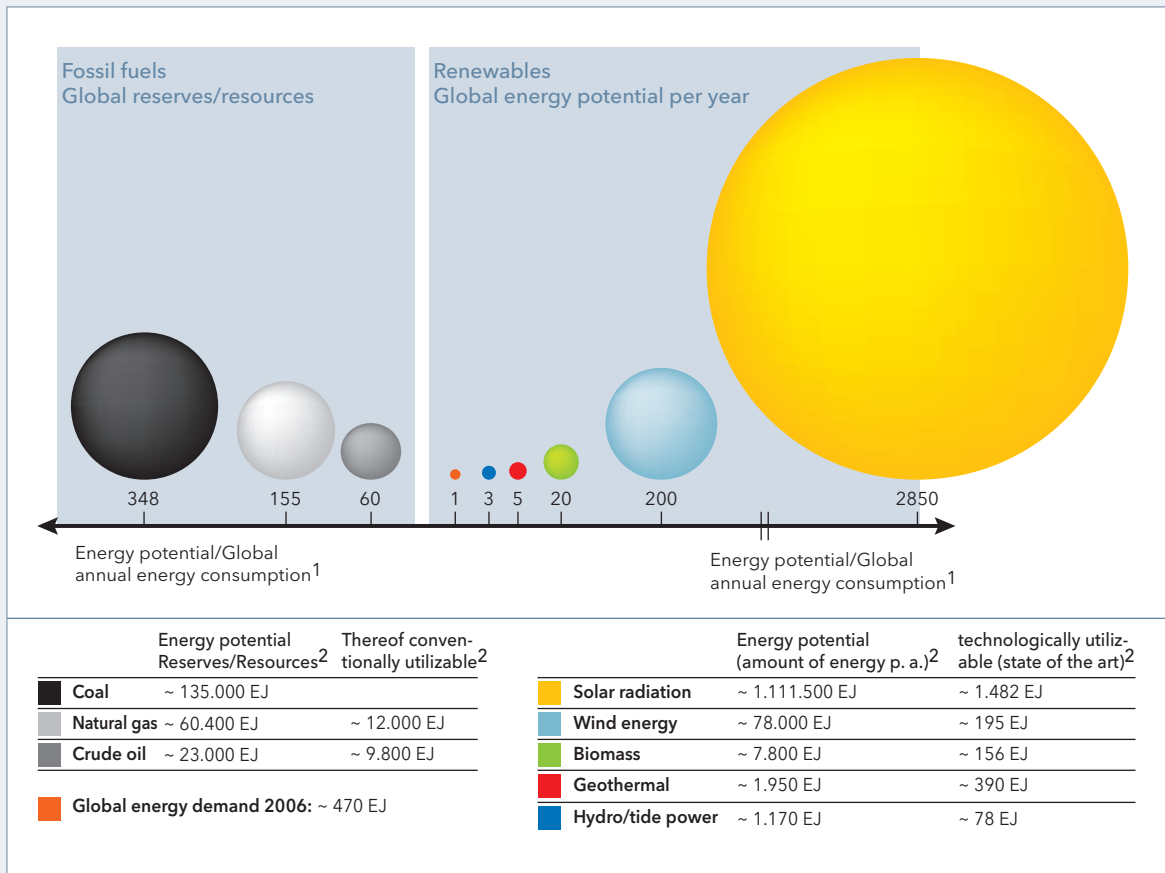

Global potential of available renewables and fossil fuels

1: Data referring to global energy consumption of 390 EJ in 1997, data from M. Fishedick, O. Langniß, J. Nitsch: „Nach dem Ausstieg - Zukunftskurs Erneuerbare Energien“, S. Hirzel Verlag, 2000

2: Data source: German Federal Institute for Geosciences and Natural Resources

A prerequisite for a significant growth in energy supply through renewable energy sources are considerable cost reductions, for example by efficient economies of scale in the further development of low-cost production methods and increased efficiencies through technological innovations. In the long run, there will be no alternative to an optimized tapping of the potentials of renewable energy sources. Especially, the utilization of solar energy through solar cells and solar-thermal power plants

will play a key role. Long-term scenarios forecast that by 2100, the utilization of solar energy will meet more than 50% of the global energy demand. Whether there will be further options, as for example for a technically and economically realizable utilization of nuclear fusion, is still open at this point.

Scenario of the development of global energy demand
(source: www.solar-wirtschaft.de)

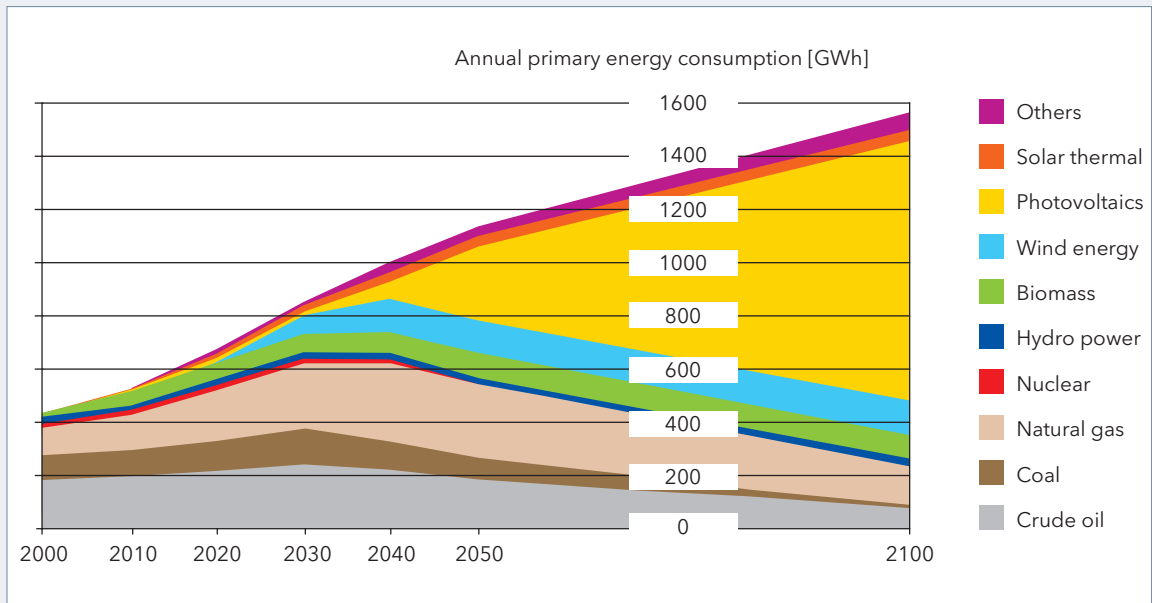

2.2 Innovation Potentials along the Energy Value-Added Chain

To secure global power supply in the long run, it is not only necessary to develop existing energy sources as efficiently and environmentally friendly as possible, but also to minimize energy losses arising during transport from source to end user, to provide and distribute energy for the respective application purpose as flexibly and efficiently as possible and to reduce energy demand in industry and private households. Each sector of the value added chain bears potentials for optimization which could be tapped through the application of nanotechnologies. All in all, the implementation of nanotechno-

logical innovations, especially in the energy sector, depends to a large extent on the political, economical and social environment and general conditions. The answer to the question which technological development will finally find acceptance, is thus determined, above all, by economical necessities and political and social parameters, apart from the technological feasibility.

Measured values for energy units

The internationally acknowledged measurement for energy is Joule ($\text{kg} \cdot \text{m}^2/\text{s}^2$). Common units in the energy sector are also kilowatt hours, hard coal units, tons of oil equivalents (TOE) or, in the Anglo-Saxon region, the British thermal unit (Btu).

Conversion factors:

Kilowatt hour 1 kWh = 3.6 MJ

Hard coal units (HCU) = 29.3 MJ

Ton of Oil Equivalent (TOE) 1 TOE = 41.87 GJ

British thermal unit (Btu) 1 Btu = 1.05506 kJ

Prefixes for decimal powers:

k (kilo) = 10^3 , M (mega) = 10^6 , G (giga) = 10^9

T (tera) = 10^{12} , P (peta) = 10^{15} , E (exa) = 10^{18}

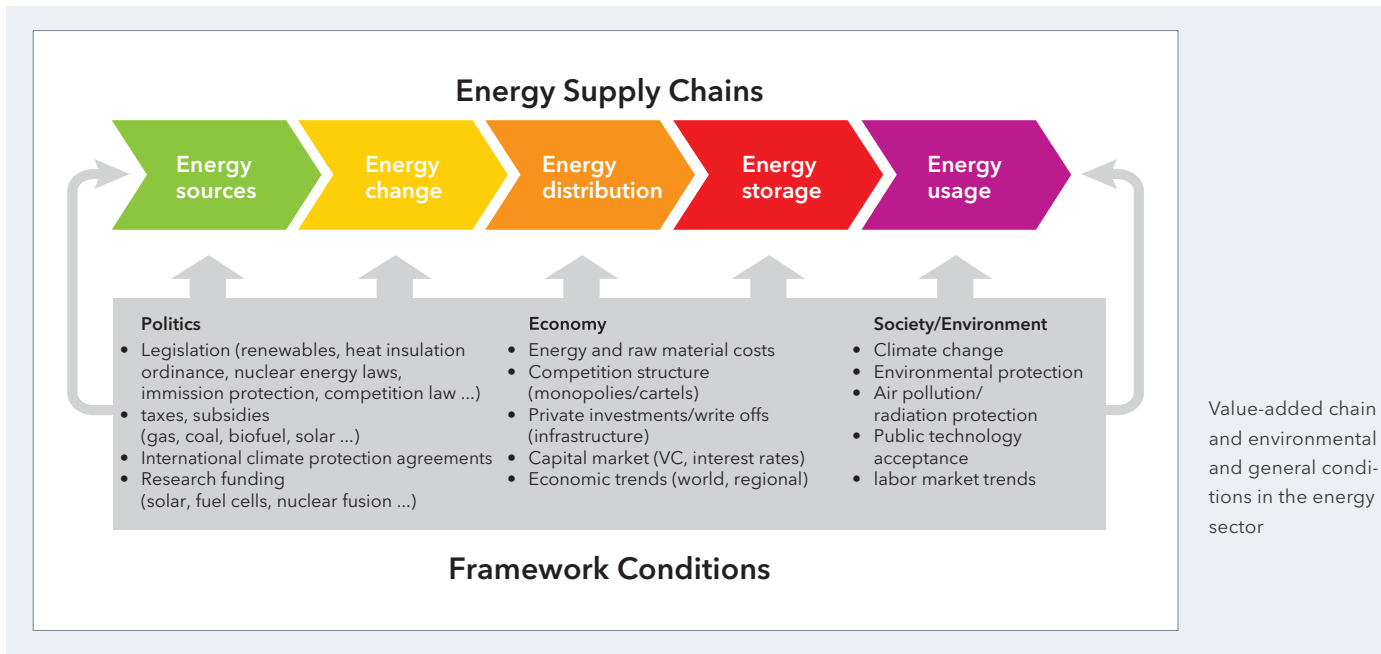

2.2.1 Development of Primary Energy Sources

Photovoltaics

The world market for solar energy is assessed at approx. 16 bn \$ in 2007 and will presumably reach a volume of 30 bn \$ by 2010 (source: CSLA). In the last year, two-digit growth rates were achieved in the booming photovoltaics market, especially in Japan, Germany and the USA, which are expected to continue also in the years to come. Studies by German Shell and the European Photovoltaic Industry Association (EPIA) and Greenpeace go on the assumption that in already two or three decades, solar technology will be able to supply 20% to 30% of the energy required worldwide. In Germany, approx. 50.000 people are employed and about 150 companies are working in the solar industry achieving a

turnover of approx. 4 bn Euro (source: Federal Association of the Solar Industry). Independent of these impressive figures, the production of solar energy is currently still not competitive. Due to high material costs and insufficient quantity of components resp. assembly elements for solar modules, the production costs of solar energy in Germany are more than three times higher than for conventional power plants.

Left: World market solar energy (source: CLSA study "Solar Power" July 2004)



Right: Market shares of different solar cell types worldwide in 2006 (source: Photon International March 2007)

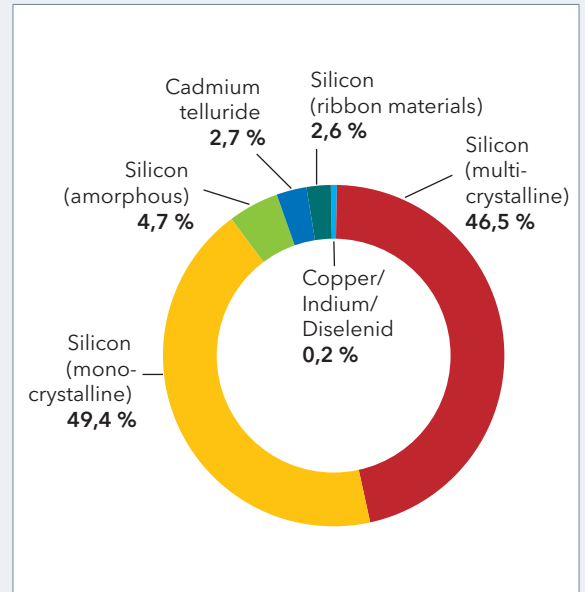

Photovoltaics will achieve a broad breakthrough, independent of state subsidies, only if it is possible to economically equip large surfaces with solar cells. This requires not only an efficiency increase in energy conversion, but first and foremost also less expensive materials and production processes, which could be enabled through the application of nanotechnologies.

Today's market dominating technology, which uses monocrystalline or multicrystalline silicon wafers, hardly allows cost reduction through technological improvements and mass production. The major constraint here is the high raw material price of the high-purity crystalline raw silicon, which, owing to bottlenecks in production, has risen by 500% since 2004. Thus, in the medium to long run, promising market potentials will result from the further development of alternative cell types such as thin-layer solar cells (inter alia, of silicon or other material systems like copper/indium/selenium), dye solar cells or polymer solar cells.



The 64-megawatt parabolic trough power plant "Nevada Solar One" in the US-state of Nevada, on stream since June 2007, supplies approx. 129 million kilowatt hours (kWh) of solar energy each year (source: Schott).

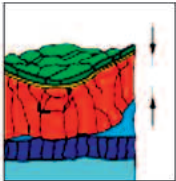
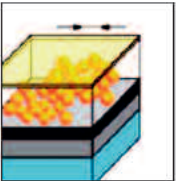
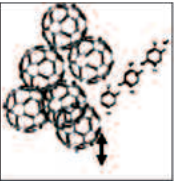

Off-grid power supply through solar plants is profitably applicable especially in economically underdeveloped regions, as for example in some regions of Indonesia (source: Schott).

| Type of solar cells | Wafer based | Thinfilm | Electrochemical | Electrochemical |
|----------------------------------|---|---|--|---|
| Structure |  |  |  |  |
| Materials | Crystalline Silicon | Amorphous Silicon CIGS cadmium telluride | Dye solar cells, nanoporous titanium dioxide | Fullerenes (C60) conjugated polymers |
| Efficiency (State of the art) | 25 % | 19 % | 10 % | 5 % |

Basic structure and efficiency of current solar cell types (source: HMI: Results of the workshop "Nanotechnology for sustainable power supply", November 29-30, 2007, Berlin). Further information on solar cell types: www.fv-sonnenenergie.de/forschungsthemen/photovoltaik

Nanotechnology companies in the field of material and module production can substitute a great deal of the added value of conventional silicon cells resp. tap additional market potentials through drastic cost reductions. Mainly polymer solar cells are said to have a high potential especially for the supply of portable electronic devices, due to their cheap materials and production processes as well as their flexible design. Further application potentials are provided for self-sustaining and mobile product-integrated applications in traffic-control systems, safety and telecommunication systems as well as at off-grid sites in developing and newly industrialized countries for locations with high solar radiation. Medium-term development targets regarding polymer solar cells are an efficiency of approx. 10 % and a lifespan of several years, for which, however, basic progress in the understanding of function and influence of nanomorphology of organic semiconductors is required. Also required are new concepts to achieve cost-effective electrode materials and effi-

cient encapsulation of cells, which are important prerequisites for economic mass production. Nanotechnologies also contribute to the optimization of conventional crystalline silicon solar cells which dominate the photovoltaics market with a market share of 90 %. Here, increases in efficiency may be achieved by nanostructured anti-reflection layers, which provide higher light yield.

Such anti-reflection glasses have already been commercially marketed and show high growth rates for application not only in photovoltaics but also in solarthermy (see page 24).



Offshore wind park
in Sweden
(source: Siemens)

Wind Power

The world market of wind power is assessed at approx. 27 bn \$. Further two-digit growth rates are forecasted for the years to come. In Germany, wind power has become established as an important branch of industry with approx. 64.000 employees and a turnover of about five billion Euros. According to calculations of the German Wind Power Institute, more than 50 percent of all wind power plants and their components worldwide come from Germany. Today, wind power in Germany is already competitive, i.e. power generation costs are in the same order of magnitude as those of conventional power plants. The Federal Environment Ministry goes on the assumption that by 2015 at the latest, wind power will be available at the Energy Exchange at cheaper prices than power from conventional generation. In future, the further development of wind energy in Germany will be confronted with the problem of choosing the suitable sites, which will be increasingly relocated off-shore. In this case, basic problems such as maintenance will have to be solved.

Forecast of the development of the global wind power market
(data source: BTM consult March 2007)

Nanotechnologies can contribute decisively to the optimization of wind power utilization, inter alia, through high-strength lightweight materials for rotor blades based on nano-composites, tribological coatings and wear protection layers of bearings and gear boxes, conductive nanomaterials for improved lightning protection or nano-optimized energy stores, which allow more economic feeding of wind power in the grid.

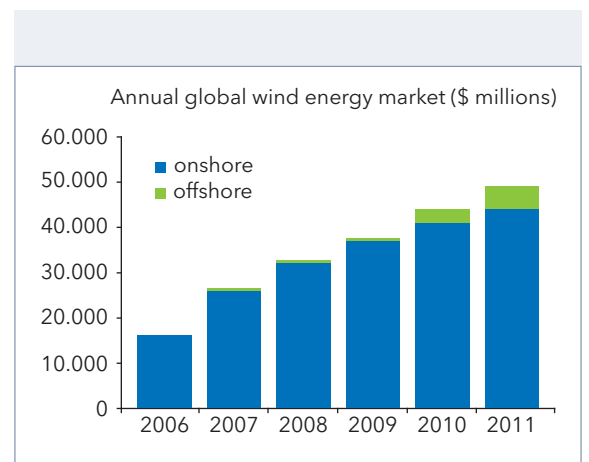

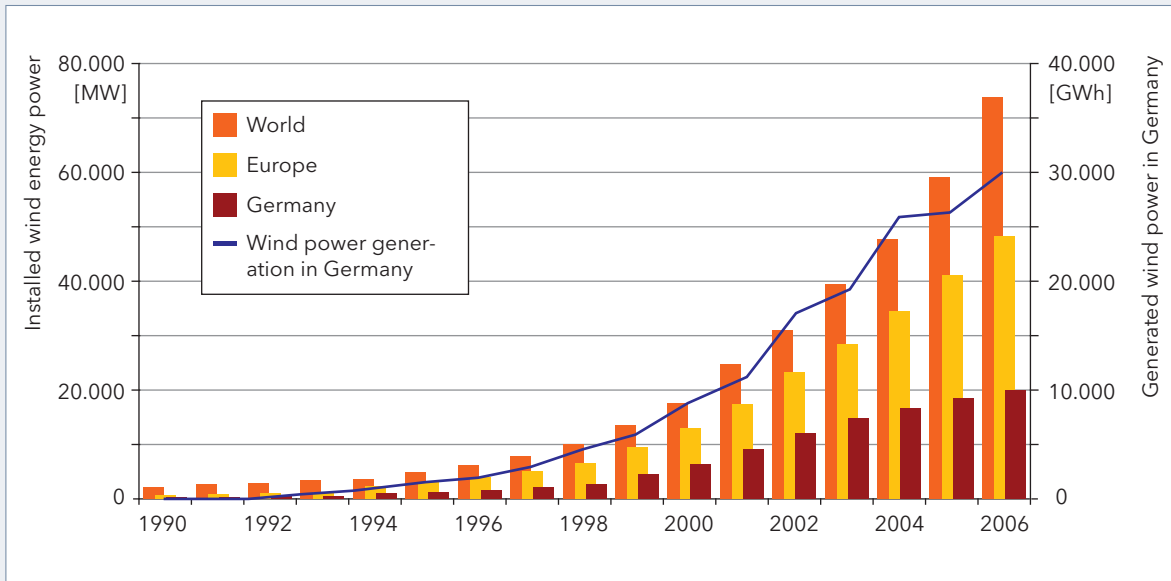

Development of the installed wind power capacity in Germany, Europe and worldwide (source: ISET 2007, data by BTM consult, wind-power monthly, IWR, ISET, BWE, WWEA)

Biomass

With a share of approx. 10% worldwide in energy supply, biomass is currently the most important renewable energy source, however with regional fluctuations regarding its utilization. On the one hand, biomass serves the generation of energy and heat, on the other hand the provision of fuels. However, the share of biofuels in the global fuel market is only approx. 1%, with bioethanol being the most important biofuel with a production volume of about 40 million t in 2006. Currently, Brazil is the major producer worldwide. Brazil, however, is criticized for sacrificing rainforest for sugar cane plantations used for bioethanol production. In Europe, bioethanol production is not yet competitive. Nevertheless, in Germany and Europe its production increased in the last years in consequence of political guidelines and high subsidies. A more competitive variant of biomass utilization is the biogenous generation of process energy from biogas. With regard to the climate change policy, the energetic utilization of biomass, in particular of biofuels however is not undisputed, since it requires great land resources and competes with food production.

Thus in future, alternative raw material sources are in demand, such as algae, domestic waste, paper or lignocelluloses-containing residual products like straw or hay to produce biofuels of the second generation on an industrial scale. Prior to this, however, basic process innovations are required. Nanotechnologies may contribute to the optimization of energetic biomass utilization, for example in the development of new conversion methods (catalysts, process technology and sensorics) as well as in the nano-optimized cultivation of bio-resources (e.g. efficient utilization of fertilizers and pesticides through nano-encapsulation and nano-sensors).

Solarthermal Energy

In future, solarthermy will play a growing role in the utilization of solar energy, since it enables the relatively cheap provision of both electric power and heat. Solar-thermal heat supply in buildings occurs decentralized through roof-mounted solar collectors, which convert solar energy into heat with efficiencies of approx. 60-70 %. Solarthermy can also be used on an industrial scale for power generation in solar power plants. Here, solar energy is being concentrated e.g. by parabolic mirrors, which will afterwards be used for steam generation and the ensuing power generation. In comparison to photovoltaic power generation, solar-thermal power plants are currently more economic and, in approx. 5 to 10 years, solar energy at locations in Southern Europe is expected to be competitive compared to electric power from fossil fuels. Two large solar-thermal power plants with a capacity of 50 MW each are currently being built in Spain, lead-managed by Germany. Conceivable are also solar chimney power plants, using thermal air flows through heated air layers for power generation.

The impact of nanotechnologies on individual components and optimized materials will become noticeable in such fields (e.g. anti-reflection coatings for optimized energy yield, optimized phase-change stores and heat exchangers or carbide coatings of collectors, which enhance energy absorption as well as thermal and mechanical stability).



Receiver in solar-thermal parabolic trough power plants (source: Schott)

Principle of a solar-thermal parabolic trough power plant. Inside the vacuum tubes, a heat carrier is heated to almost 400 °C through concentration of sun rays by means of mobile parabolic reflectors. The heat thus gained generates steam for a downstream steam power station (source: EECH AG)

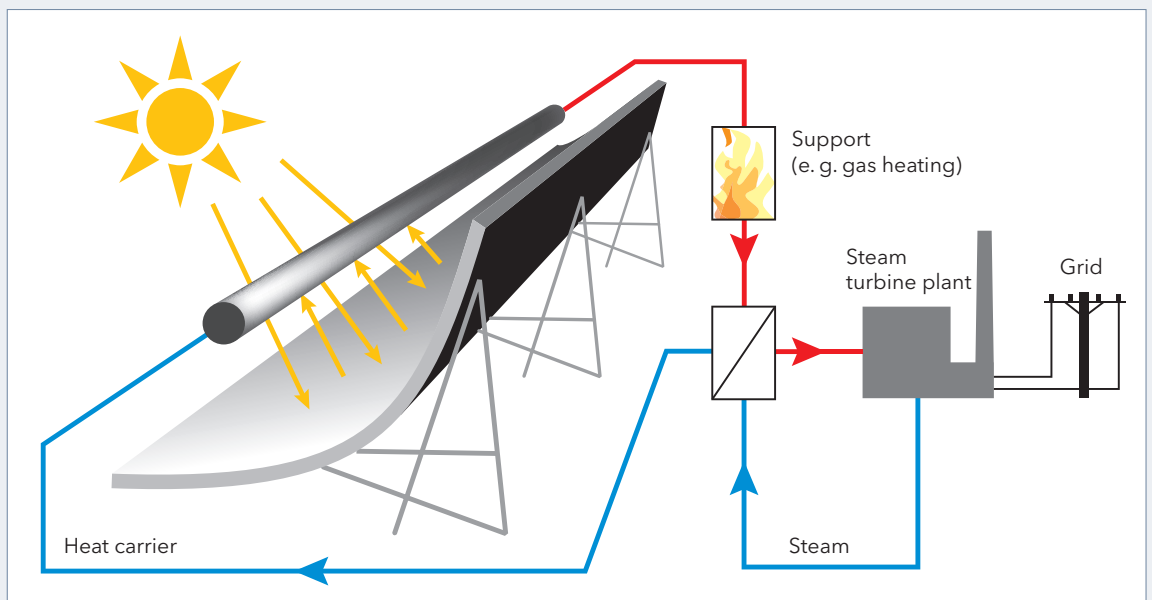



The world's largest gas turbine with a capacity of 340 MW installed in a power plant in Irsching which began trial operation at the end of 2007. The overall efficiency of the power plant is stated to be approx. 60% (source: Siemens).

Geothermy

Geothermy is a long-range energy source with deposits capable of meeting a multiple of the global energy demand. Geothermy provides the possibility of decentralized direct use of heat or the conversion into electric current in geothermal power plants. With regard to the optimization of efficiencies, combined heat and power generation is ideal.

In Germany, economically utilizable geothermal energy deposits can often only be developed through depth drilling in depths of more than 2 km. A nanotechnological application potential, for instance, is the improved wear protection through nanostructured hard layer systems for geothermal drill probes exposed to extreme stress in depth drilling.

What is also energetically favorable is the combined utilization with heat pumps or solarthermy. Here, surface-near heat reservoirs (approx. 14°C in 100m depth) are used for heating in winter which are regenerated again during the cooling process in summer.

More information: www.energieland-hessen.de

2.2.2 Energy Conversion

In the field of energy conversion, innovation potentials are mainly provided through the improvement of conversion efficiency, for example in the generation of electric power from fossil fuels through turbines or fuel cells, in combustion and electric engines, in thermoelectric energy conversion as well as in the generation and conversion of chemical energy sources. Apart from generation of electric current and heat through stationary large-scale power plants, decentralized and mobile energy converters like fuel cells or thermoelectrics will play a growing role in future. The conversion of fossil fuels into electricity, heat and kinetic energy form the backbone of today's energy supply. Conversion processes of utmost efficiency are required to save resources and reduce CO₂-emissions. Optimization potentials are given, in particular, in coal-fired power plants, which have a great share in global power generation. Coal-fired power plants in operation worldwide have an average efficiency of approx. 30%, while new plants show efficiencies of more than 45%. Gas turbine power plants reach efficiencies of almost 60% already today. The complete replacement of the coal-fired power plants worldwide with modern plants would result in a reduction of the CO₂-emissions of 35% compared to conventional coal power generation.

Rotor and combustion chamber of a gas turbine. More heat resistant materials provide for further increase in operating temperatures and thus in efficiencies of gas and steam turbine power plants (source: Siemens)

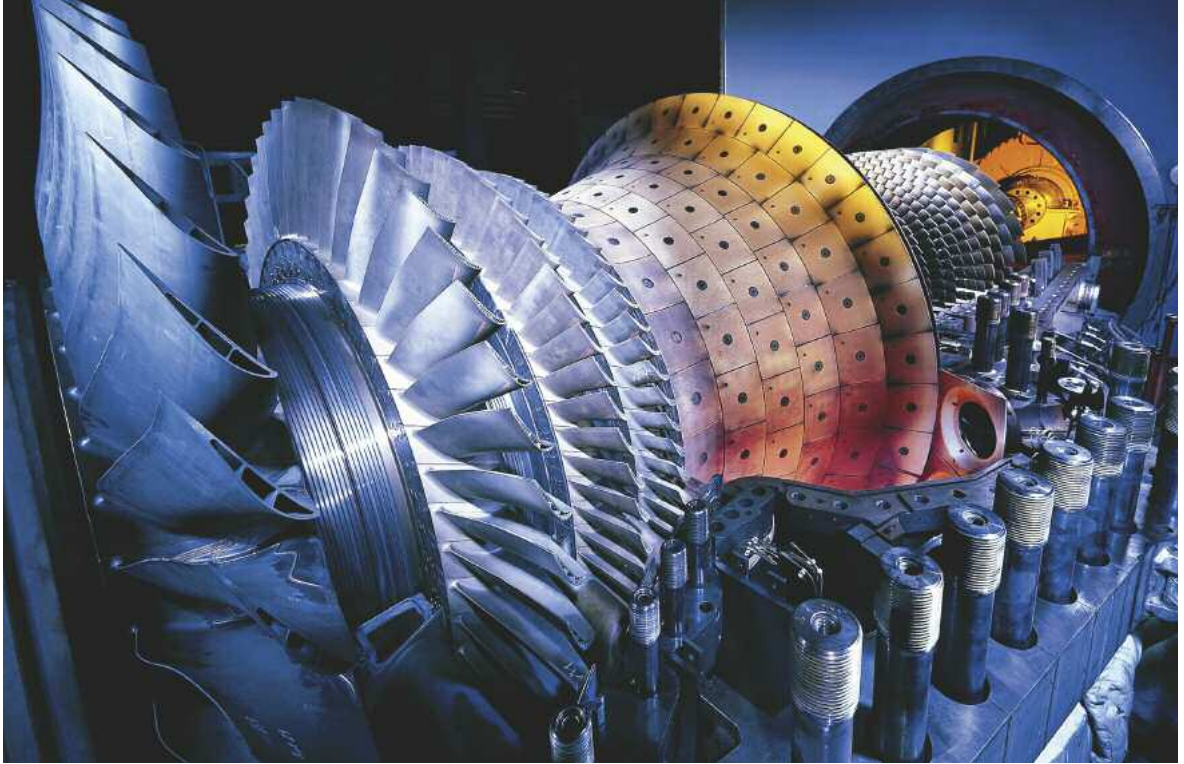

Optimizations through a further increase in power plant efficiencies, while basically maintaining the power plant process, require higher operating temperatures. New materials with extreme heat resistance, for example based on nanotechnology, will have to be developed. Improvements will be achieved, inter alia, through optimized thermal barrier layers for turbine materials based on nanoscale gradient layers. One development objective for the next 10 years is to raise the admissible hot-gas temperatures in gas turbines to over 1600 °C, thus increasing the efficiency of the power plant significantly to over 60 % (without power-heat coupling). Lightweight materials, like titanium aluminides, with nano heat-protection can be utilized for more efficient turbines in aircraft engines. Further potentials for the reduction of CO₂-emission are provided by separation and sedimentation procedures in subsurface storage sites. According to the process type, separation technologies with a CO₂-retention of 85-100 %, however, entail losses in the overall efficiency of approx. 10 %.¹ In Germany, the first CO₂-free brown coal power pilot plant worldwide is currently being built according to the so-called oxyfuel method. Completion is expected in 2008. Nano-optimized membranes for gas separation can render CO₂ separation more efficient.

¹ D. Golschmidt: „Neue Werkstoffe für effiziente Kraftwerke“, presentation by Siemens Power Generation at the WING Conference, October 22-24, 2007, Berlin

Fuel Cells

Fuel cells convert chemical energy with a high efficiency directly into electric current. Apart from pure hydrogen, also natural gas, methanol, benzene or biogas may be used to operate fuel cells. In a reformation process, “on-board” if possible, the required hydrogen is extracted from these fuels. The potential application spectrum of the fuel cell reaches from power supply to mobile phones or laptops and drives of electric vehicles as well as heat and electricity supply of houses up to small power stations. An important field of application is also the Uninterruptable Power Supply (UPS), for example in the field of information and communication technology or for “premium applications” like yacht engines. Depending on the field of application, different fuel cell types based on different material systems are applied, with operating temperatures ranging from room temperature to up to 1000 °C. Here, particularly attractive are high-temperature fuel cells like MCFC (Molten Carbonate Fuel Cell) or SOFC (Solid Oxide Fuel Cell), since they enable the realization of power-heat coupled systems with high overall efficiencies. Such fuel cells are compatible to the existing supply infrastructure. They are already on the verge of broad commercial realization and could thus contribute decisively to an increase in energy efficiency.

High potentials are also seen in mobile fields of application. For the broad application in cars, an adequate infrastructure, as for example a distribution net for hydrogen, methanol or natural gas as well as technical and economic competitiveness compared to combustion engines is still wanted. In the short run, a widespread realization seems to be possible for the application of miniaturized fuel cells for the operation of mobile electronic devices, which are able to be operated with e.g. methanol, but which are not yet standard. Innovation potentials for fuel cells resulting from nanotechnologies are mainly due to higher electricity yield from the conversion of chemical energy, especially through nanostructured electrodes, catalysts and membranes. At the location Frankfurt-Höchst, the BASF division Fuel Cell (former PEMEAS) is developing safe and cost efficient high-temperature membrane fuel cells on the basis of so-called membrane electrode units, using solid, non-extractable polymer electrolytes instead of phosphoric acid-doped polymer membranes.

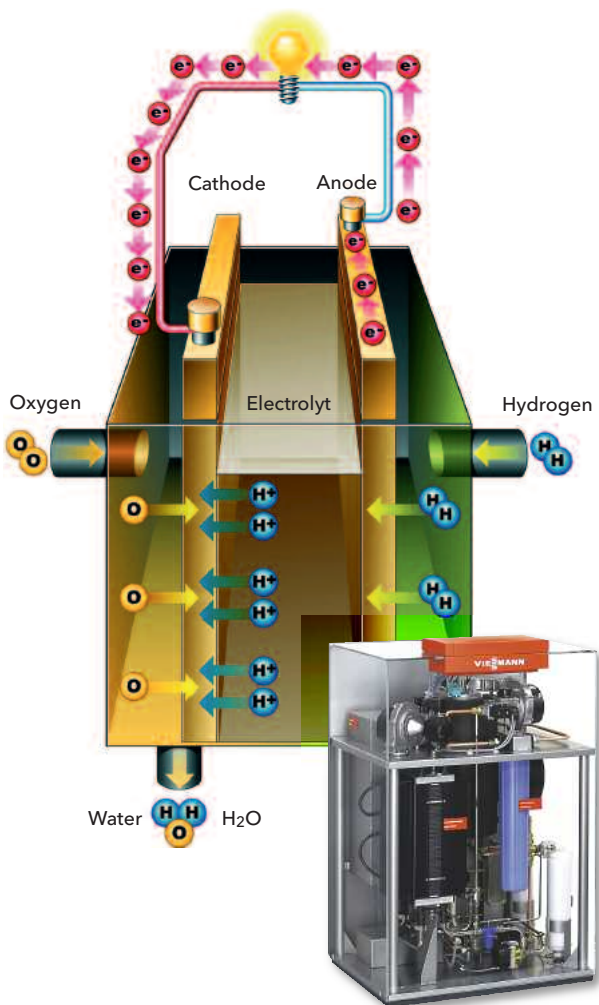

Thermoelectrics

Thermoelectrics may be used to directly convert heat into electric energy by utilizing the Seebeck-effect. The Seebeck-effect describes the development of voltage between two points of an electric conductor with different temperatures. The bigger the temperature difference, the more energy can be generated by thermoelectric generators. Desired material properties in thermoelectrics are low heat conductivity in connection with good electric conductivity, which has a direct impact on the thermoelectric efficiency determined by the nondimensional parameter ZT ("Figure of Merit"). The materials used are semiconducting solid compounds, usually silicon/germanium alloys, for example, which achieve efficiencies between 5 and 10% at a temperature gradient of 700°C and are efficient in niche applications, at the most. Nanotechnological innovations could give a boost to thermoelectrics through significantly improved efficiencies demonstrated in current research works. Nanostructured semiconductors with optimized boundary layer design could help realize increases in efficiency which might pave the way for a broader application of waste heat utilization, e.g. in cars, or of human body heat for portable electronics in textiles (cf. section 3.2).

Top left: Schematic diagram of a fuel cell. At an electrolyte/electrode unit, gaseous hydrogen or a hydrogen-containing fuel with air oxygen is electrochemically converted into water and electric current is generated.

Bottom left: Prototype of a house energy center on the basis of a PEM-fuel cell coming on the market from 2010. It is expected to cover the basic power and heat demand of a single-family house. Development goals are electric power of 2 kilowatt and heating power of 2.5 kilowatt. The electric efficiency is said to be more than 32%, the overall efficiency at least 87% (source: Viessmann)

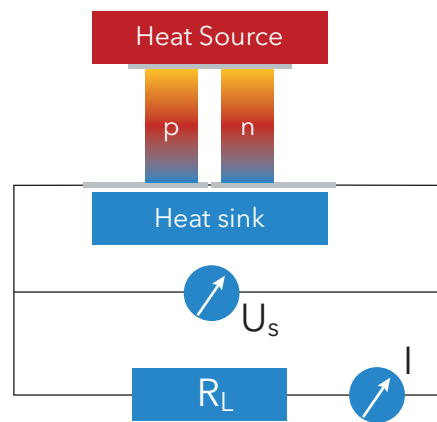

Schematic structure of a thermoelectric energy converter utilizing the Seebeck-effect. In n-doped material in the warm area, more electrons are raised from the valence band to the conduction band and are available as charge carriers; correspondingly, in p-doped material more electron holes are available. This potential difference causes the generation of an electric current flow.

Combustion and Electric Engines

A significant part of the global energy consumption is attributable to the motorized individual traffic. Thus, a further increase in efficiency of combustion engines could help save considerable amounts of energy. Nanotechnologies provide solutions, for example, through wear protection layers for engine components or Diesel injectors, which provide higher injection pressures and therefore improved energy yield (cf. brochure Automotive Nanotechnologies). Nanoparticulate Diesel additives based on cerium are being tested, which are said to optimize combustion in Diesel engines and to allow fuel savings of 5-10%.

In the long run, the development of electric engines could also benefit from nanotechnology developments. Nanostructures provide the key to further optimization of superconductor technology. Material improvements for high-temperature superconductors will allow for significantly higher power densities and thus high-efficient and powerful electric engines and generators. Fields of application are, for instance, ship engines (in the long run, also aircraft engines are conceivable) or generators for power generation coupled to gas turbines or ship aggregates.

Generation of Chemical Energy Sources

For the storage of large energy amounts, chemical energy stores able to assure supply guarantee, even at seasonally strongly fluctuating demands, are indispensable in the long run. Currently the chemical storage of energy is, to a large extent, based on the fossil fuels coal, oil or gas. For their recovery from the deposits, highly stressable drill probes and conveying systems are required, the wear and corrosion resistance of which can be enhanced by nanomaterials and nanolayers. For the production of liquid fuels from fossil energy sources, nanostructured catalysts like zeolites are applied in oil refinement. Further potentials are provided to render coal liquefaction for fuel production economically competitive by means of improved catalysts.

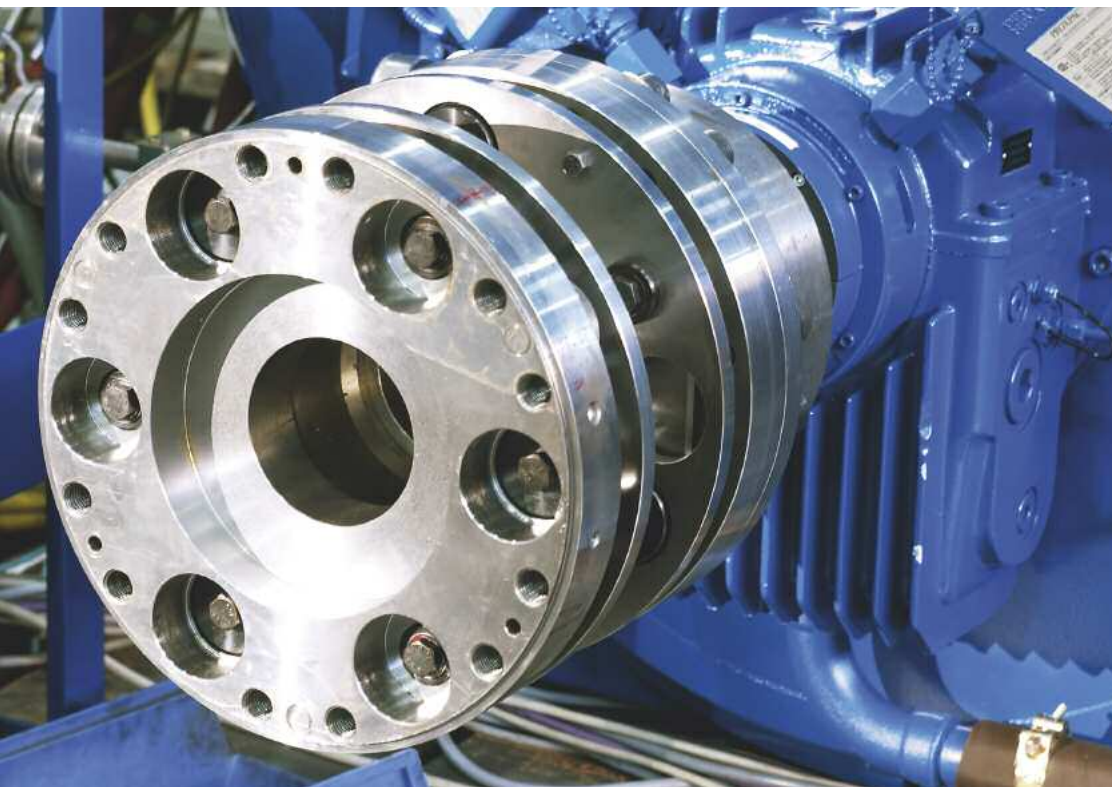

Electric engines on the basis of high-temperature superconductors for use in ships. The power density of superconductors is 100 times higher than that of conventional copper windings. This allows significant savings in mass and volume while efficiency increases, since no electric losses occur in the superconductor. In comparison to Diesel engines, electric engines are clearly quieter and advantageous, above all, in case of strongly varying power demands, e.g. on cruisers and yachts with many berthing maneuvers (source: Siemens).



Hydrogen-driven F-cell vehicle from Daimler at Frankfurt Airport.

In the long run, high hopes are pinned on hydrogen as a promising energy source for environmentally friendly power supply, since its availability is unlimited and pollutants do not occur in conversion. In the economic and ecological evaluation of the utilization of hydrogen as an energy source, substantial energy losses have to be considered, which occur in the conversion chain from production over transport and storage to use, as well as the required massive investments in a new supply infrastructure. Currently, various pilot projects for the development of a hydrogen infrastructure are being initiated, in which especially automobile groups and gas suppliers are involved. At the moment, already 300 hydrogen fueling stations are operated or planned, above all in the USA, in Europe and Japan (see www.h2stations.org). The US state of California is planning a "hydrogen highway" by 2010 with about 200 supply stations. In November 2006, a hydrogen fueling station was opened in the industrial park Frankfurt-Höchst, which utilizes an already existing large hydrogen source (30 mn m³/year). This hydrogen occurs as a byproduct in chemical production and is pumped to the fueling station via a long 1.7 km pipeline. Cars will be able to refuel hydrogen both in liquid form, i.e. at cryogenic temperatures of -253 °C and in gas form with 350 and 700 bar (see www.zeroregio.de).

According to a study by Linde, about 6 million hydrogen-driven cars could roll on the streets of Europe by 2020.

This would require investments of billions in hydrogen production (by electrolysis plants or reformers) as well as in the infrastructural sector and depends strongly on the development of the general political conditions. Basic prerequisites for a broad use of hydrogen, however, are the inexpensive availability of renewable energy sources and technologies for the efficient production and storage of hydrogen. Here, nanotechnologies could contribute both to efficiency increases in the electrolytic production of hydrogen and to the establishment of alternative methods, such as hydrogen production in bioreactors or photoelectrolytic H₂-production (cf. section 3.2).

2.2.3 Energy Storage

Energy stores are indispensable at different points of the supply chain from energy conversion to end user. What is mainly relevant is the storage of electric current as the most universal energy source, which is reversibly stored either as electric energy or in the form of other kinds of energy, like chemical energy (e.g. hydrogen storage) or mechanical energy (pressure accumulator and pumped storage). In addition to this, the storage of heat energy, above all for heat supply in buildings, plays an important role.

Pumped Storage and Compressed-Air-Storage

Usually, pumped storage hydro power stations are used to store large amounts of electric power in the grids. In case of excess power, water is pumped into a storage lake situated at a higher level, which can be discharged if required and the water can be used for power generation through turbines. Thus large amounts of energy can be stored with an efficiency of approx. 80 % and fed back to the grid in the form of electric current to cover short-term peak demands. The increasing number of renewable energy sources with discontinuous, fluctuating power demand results in increasing requirements for power stores in the grid, which have previously mainly been used to profit from the price differences between off-peak and on-peak demand, and which were able to cover peak demand even without the extension of the maximum grid capacity. To compensate power fluctuations of wind and solar energy plants, pumped storages are suitable to only a limited extent, since they are usually too far away from the feeding sources (especially in case of wind energy) and further extension is ecologically critical due to high landscape consumption. Therefore, to meet the growing demand for efficient power stores, other kinds of storage, such as compressed-air stores are used, where air is pumped into subsurface chambers by means of electric compressors and, if required, electric current can be recovered using gas turbines. A disadvantage of this technology is the relatively low efficiency of currently approx. 55 %, which could be increased to approx. 70 % through the recovery of heat from air compression. Electrical energy stores like lithium-ion batteries are also considered as alternatives, especially for decentralized energy storage.

Basic structure of lithium-ion batteries (source: Evonik)

Electrical Energy Storage

The most important application field of electrical energy stores is the supply of mobile electronics and, in future, increasingly of hybrid and electric vehicles. Electrochemical stores (batteries, rechargeable batteries, supercapacitors) with higher efficiencies, energy and power densities in comparison to other power stores, are advantageous in this field. Regarding the demand on electrical energy stores in the individual applications, a number of criteria have to be optimized, inter alia, energy and power density, lifespan, reaction time, operating temperature range, safety and efficiency. Many of these performance features can be optimized through the application of nanotechnologies. Examples are lithium-ion batteries which are regarded to be the power storage variant with the most promising future, due to an excellent energy and performance density. Application potentials are seen in electric vehicles, but also in power stores in wind farms to bridge the gap between power demand and fluctuating power generation. In future, electric vehicles equipped with lithium batteries, which draw excessive power from the grid and would be able to feed it back if required, could be a possibility for a smart and decentralized energy storage system. Nanotechnologies could help enhance the capacity and safety of lithium-ion batteries, but also of other battery types like nickel hydride batteries (cf. section 3.3).



Storage of Chemical Energy

In future energy systems, chemical energy, in particular hydrogen, recovered from renewable sources will play an increasingly important role. Apart from necessary infrastructural adjustments, efficient hydrogen storage is regarded to be one of the critical factors of success on the way to a possible hydrogen management. In addition to conventional high-pressure stores or liquefied gas stores, industry uses in particular chemical H₂-stores of metal-hydride compounds. However, the storage procedures currently available still bear some disadvantages, which are prejudicial to broad economic application. High-pressure stores are very heavy and liquefied gas stores are expensive due to the costly insulation, which is required to minimize losses through hydrogen evaporation. Metal-hydride stores also entail high costs and are relative heavy. Furthermore, materials currently used for chemical storage do not meet the demands of the car industry, which requires, for example, H₂-storage capacities of up to ten percent by weight. Various nanomaterials, inter alia on the basis of nanoporous metalorganic compounds or metal hybrids provide development potentials, which may be profitably realized at least in the operation of fuel cells in portable electronic devices. The storage of fuels on hydrocarbon basis, like petrol, can also be optimized through nanotechnology. With nanostructured fillers in polymers, for example, the diffusion density of plastic tanks and pipes can be increased and undesired emissions and fuel losses reduced.

Heat Stores

Heat stores play an important role in the heating of buildings through solarthermal panels. In order to increase the solar share in the annual useful heat, heat stores with high capacities are required, which make the solar heat stored in summer available in winter. Another concept is based on adsorption stores like zeolites, which dry up when heat is supplied and can be discharged when humid air passes through. The heat results from the adsorption heat of the water molecules in the nanometer-sized pores of the zeolites. New concepts are based, inter alia, on the application of phase-change materials, which absorb heat through a reversible phase transition in the operating temperature range and emit it to the environment again. Nanotechnologies play a role in the development of micro-encapsulated phase-change stores which are used for thermostatization in buildings (cf. brochure Uses for Nanotechnologies in Architecture and Civil Engineering).

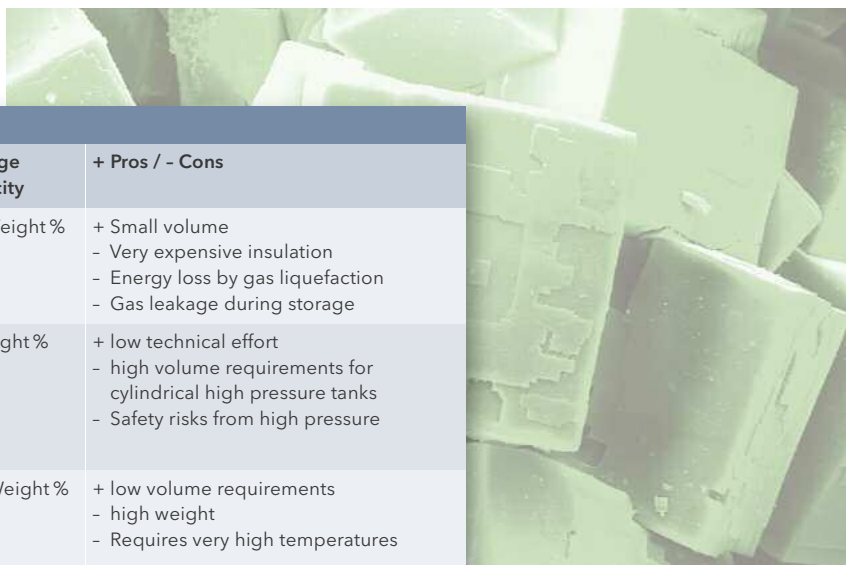

Nanocubes (source: BASF)

| Overview on types of hydrogen stores | | | | |
|--|----------------------------|---------------------|------------------|---|
| Storage medium | Temperature resp. pressure | Mass* resp. volume* | Storage capacity | + Pros / - Cons |
| Liquid hydrogen | -270 °C | 140 kg, 86 l | 7,5 Weight % | + Small volume - Very expensive insulation - Energy loss by gas liquefaction - Gas leakage during storage |
| Gaseous hydrogen | 700 bar | 125 kg, 260 l | 6 Weight % | + low technical effort - high volume requirements for cylindrical high pressure tanks - Safety risks from high pressure |
| Nanoscale metal hydrides (e.g. MgH ₂) | > 300 °C, 8 bar | 175 kg, 73 l | 4-7 Weight % | + low volume requirements - high weight - Requires very high temperatures |
| Nanoporous metal organic materials (MOFs) (e.g. MOF-177) | < -210 °C, > 50 bar | 86 kg, 160 l | 7,5 Weight % | + low weight - low temperatures - high volume requirements |

*calculated for a range of 500 km

Data sources: Prof. Dr. Stefan Kaskel, TU Dresden, and Prof. Dr. Birgit Scheppat, FH Wiesbaden

2.2.4 Energy Transfer

In the field of energy transfer, in particular energy distribution will have to face great challenges in future regarding increases in efficiency and the adaptation to changing basic conditions. The current power grids are not designed for a massive development of renewable energy sources. Future power distribution requires grids providing dynamic load and error management, demand controlled energy supply with flexible price mechanisms as well as the possibility of feeding through a multitude of decentralized, renewable energy sources. Nanotechnologies could contribute decisively to the realization of this vision, for example through nanosensoric and power electronic components able to cope with the extremely complex control and monitoring of such power grids. Another issue to be discussed in connection with nanotechnologies is the reduction of energy losses in power transfer. Apart from further improvements regarding high-temperature superconduction, it is hoped that the extraordinary electric conductivity of nanomaterials like carbon nanotubes can be utilized for the application in electric cables. In the long run, options are given for wireless power transport, e.g. through laser, microwaves or electromagnetic resonance. Future scenarios providing for energy generation through solar power plants in space which transfer their energy to earth via laser or microwave radiation are being developed mainly in the USA. More recent research results suggest that

electric power could also be transferred by electromagnetic resonance, wirelessly and with high efficiency over longer distances, thus superseding power cables in certain applications.

2.2.5 Energy Use

In the short run, the greatest potential regarding the avoidance of greenhouse gas emissions is to be seen in the efficient usage of energy both in industry and in the private sector (cf. section 2.3). Thresholds for nanotechnology arise first and foremost in heat insulation in buildings or in thermostatization in technical processes, for lightweight construction materials on the basis of nanomaterials and composites, in the application of energy-saving lighting through light-emitting diodes. Such applications will be discussed in detail in section 3.5.

2.3 Market Potentials for Nanotechnologies in the Energy Sector

Nanotechnologies provide a number of application potentials in the energy sector. Usually they take effect at an early stage of the value added chain, namely on the optimization of materials and components, which are frequently decisive for the capacity and functionality of the whole system. As "enabling technologies", nanotechnologies often enable the realization and the economic breakthrough of new product ranges and technologies in the first place, and thus the opening up of promising market potentials. Experts expect nanotechnologies to provide optimized components and procedures, which can be profitably applied along the whole value added chain from the development of energy from primary sources to the conversion, storage, transport and use of energy. According to estimations by Cientifica, nanotechnologies will tap the greatest market potentials in the field of energy savings with approx.

40 bn \$ in the short to medium run, inter alia in the following fields of application:²:

Transport

- Lightweight construction in the transport sector through the application of nano-composites in car and aircraft manufacturing
- Higher efficiency in fuel consumption of automobiles through nanoparticulate additives or wear protection layers of engine components

² T. Harper: "Energy And Nanotechnologies: A Rational Market Based Analysis", Nano-Energie Impulsveranstaltung, June 28, 2007, industrial park Hanau-Wolfgang

Building and lighting engineering

- Thermal insulation through nanoporous material and nano-components for optimum control of light and heat flux in buildings, inter alia through switchable glasses, heat reflectors etc. The share in insulation materials for private consumption is 80% of the total market volume, with sharply increasing growth rates. Frost & Sullivan assess the European Market at 2.9 bn \$ in 2006.
- Energy-efficient lighting through inorganic or organic light-emitting diodes. LEDs are expected to have growth rates in the order of magnitude of 15-20% in the years to come, thus in 2010, a market volume of 8.3 bn \$ is expected. The growth is mainly determined by new applications like lighting, automobile headlights and the display illumination of computer and TV-screens.

In Germany, about 10 percent of the electric final energy, which makes up approx. 51 billion kilowatt hours, is used for artificial lighting, approx. 3 bn kilowatts of which could be saved through more efficient lighting. More than 50 percent of the total expenses for the energy supply of a business enterprise are attributable to lighting alone, in some companies of the wholesale and retail business even up to 70 percent. Lighting in administrative buildings is also a high-demand area, which may account for up to 45 percent and more of the whole power consumption of a building.

Energy Stores

In the field of energy storage, the nanotechnological market potentials concern first and foremost enhanced lithium-ion-batteries for portable electronics or hybrid and electric vehicles, nano-optimized supercapacitors and nanoporous hydrogen storage materials. Cientifica forecasts a growth for nano-optimized energy stores from currently approx. 1 bn \$ to approx. 5 bn \$ in 2014. The world market for lithium-ion battery materials shows a double digit growth rate and amounts to more than 1.2 bn dollar. Evonik goes on the assumption that the market volume will increase to approx. 4 bn US-dollar by 2015.

Fuel and Solar Cells

Market potentials of nanotechnology in the energy conversion sector will mainly arise in the field of thin-layer solar cells and in the fuel cell technology.

According to estimations by Cientifica, a market volume of approx. 10 bn \$ will be reached with these applications. According to an assessment of the consulting firm WTC, the world market volume of thin-layer solar cells will more than double - from currently 800 m \$ to approx. 2 bn \$ by 2010. This growth will be generated mainly beyond the material system silicon through compound semiconductors CdTe (cadmium telluride) and CIGS (Copper, Indium, Gallium, Selen), the function of which is essentially based on an optimized layer design on the nano-level (cf. practical example TU Darmstadt, p. 64).

Apart from potentially low production costs and a more flexible scalability, thin-layer solar cells bear the advantage of a more constant performance - even at fluctuating temperatures and suboptimum radiation conditions (angle of light incidence, clouds). This opens up new application fields like flat roofs or extensive solar plants.

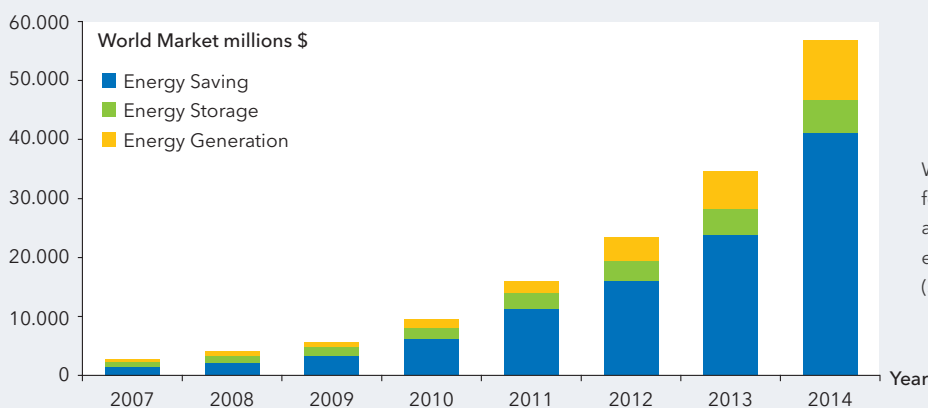

World market evaluation for nanotechnology applications in the energy sector (source: Cientifica 2007)

3 Allied Business Intelligence Inc. 2003: "Fuel Cell Industry Competitive Analysis-Assessment of Major Players, Global Markets and Technologies"

4 Press release of PEMEAS (BASF Fuel Cell) from December 14, 2006, www2.pemeas.de/news.asp

A study of the Allied Business Intelligence forecasts an increase in the global market volume for fuel cell systems to 18 bn \$ in 2013³, with a short-term dominance of stationary systems (combined heat and power and domestic plants) in the fuel cell market, while in the medium run, micro fuel cells for portable electronic devices and automotive applications will develop strong market dynamics. Assessments by BASF assume a slightly slower growth of the fuel cell market with a forecast increase of one billion Euro in 2010 to 21.5 billion in 2020.⁴ However, in the years to come, most of the turnover will still be generated by subsidized R&D-activities and pilot projects, since from an economic point of view fuel cell systems, in comparison to competing solutions, are not yet competitive in a number of applications.

High-Temperature Superconductors

The field of high-temperature superconductors (HTS) is also a promising application field of nanotechnologies, which expects a sharp market growth to a world market volume of approx. 300 m \$ in the next years.⁵ High-temperature superconductors provide potentials for more efficiency and energy savings in many supply chain sectors, such as in energy storage (e.g. centrifugal mass stores for low-loss storage of electric current through conversion into rotational energy), in energy transport (low-loss electricity transport and power supply through HTS cables, current limiter and transformers), in energy conversion (efficient electric drives and generators) as well as in energy usage (e.g. induction heater in metal processing).

Thermoelectrics

Currently, thermoelectric energy converters are still niche applications, but even in this sector it will be possible to tap new market potentials through nanotechnological applications. The world market for thermoelectric energy converters (cooling, generators) is presently being assessed at approx. 1 bn \$. In the medium run, waste heat usage in the automotive sector provides a high energy savings potential, since approx. 2/3 of the energy input into an automobile are lost as waste heat. In Germany alone, the theoretical energy savings potential through thermogenerators would be approx. 10 TWH per year, if all cars were equipped with 1 KW thermogenerators. In reality, we are still far from it, and in the automotive industry solely some pilot developments are being pushed.

BMW, for example, plan to realize a 750-Watt generator in the 5 series by 2011.⁶

Forecast development of the world market for thin-layer solar cells; CIGS: Cadmium, Indium, Gallium, Selenium; CdTe: Cadmium telluride; multi-junction: Cells with several layers of different semiconductor materials; a-Si: amorphous silicon (source: WTC 2007: "CdTe leads the pack in thin-film solar business", Think Small No. 5 vol. 2, November 2007)

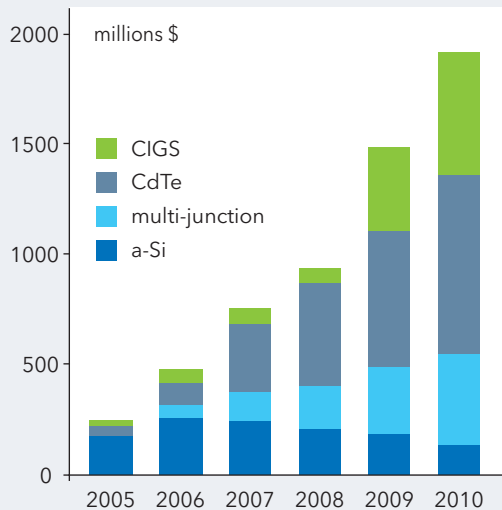

Forecast market volumes for fuel cell systems (source: NRI-IFCI 2007: "The Future of Fuel Cells", National Research Council Canada, Institute for Fuel Cell Innovation, data from "Fuel Cell Industry Competitive Analysis-Assessment of Major Players, Global Markets and Technologies", Allied Business Intelligence Inc., 2003)

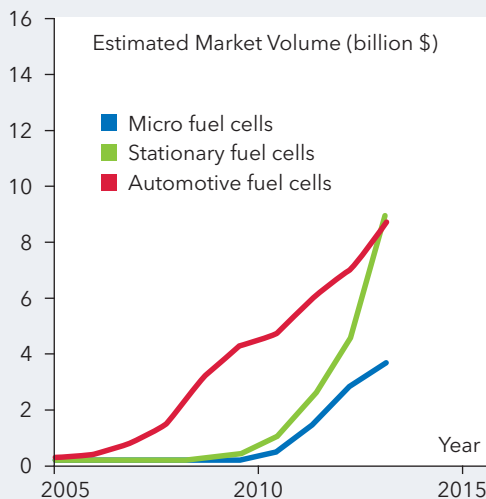

5 Source: EnergieAgentur NRW: „Innovation & Energie“, 3/2007

6 Source: H. Böttner: „Nanoskalige Materialien für thermoelektrische Anwendungen“, presentation at the event WING 2007, October 22-24, 2007, Berlin

Energy and CO₂ Savings Potentials Through Nanotechnologies

As cross-sectional technologies, nanotechnologies will enable increases in efficiencies and energy savings in many fields of the energy sector. However, due to the complexity of the applications and a blurred delineation of the subject area, precise statements regarding the quantitative energy savings potential through nanotechnologies are currently not available. First approaches towards this goal were made, for example, by means of a study which attempted to calculate the energy savings potentials through nanotechnologies for some selected technology lines in Germany. For the selected applications fields of transport, lighting, heat supply and heat demand, an energy savings potential of 283 PJ by 2025 was determined for Germany, which corresponds to a reduction of the total power demand of 3.1% compared to the reference year 2004.⁷ Although the relative savings potentials for individual applications are in the order of magnitude of up to 40% in relation to the original power demand (for example, 30% for LED-lighting or 36% for nanostructured heat barrier materials), the absolute effect in relation to the total power demand is to be assessed as rather small. With approx. 0.003% in relation to the worldwide emissions, the short-term effect of nanotechnologies on the avoidance of CO₂-emissions is almost negligible, according to evaluations by Cientifica.⁸

These rather pessimistic evaluations are based on the inclusion of only a few application examples of nanotechnologies. Considering the broad cross-sectional and leverage effect in many industrial fields of application, the energy savings and efficiency potential through nanotechnologies is to be assessed as significantly higher, at least in the medium to long run. This applies not only to the use of renewables, for example through nano-optimized photovoltaics, but also to energy savings in conventional processes. The manufacturing of cement, with 2 billion annual tons the quantitatively most manufactured industrial product worldwide and responsible for 5% of the global CO₂-emissions, is only one example.

In the application of cement, savings in raw materials of approx. 60% and in CO₂-emissions of approx. 40% would be principally possible through nano-optimized ultra-high performance concrete with 10 times the strength of standard concrete, since much less material is required to fulfill the same mechanical demands. A good portion of these potentials, however, will only be tapped in the long run, since in many fields marketability and market penetration are still too low. In the short run, nanotechnologies will rather be able to contribute to savings in CO₂-emissions in conventional energy generation methods, especially through increases in efficiency, as well as through more efficient energy usage (e.g. in the fields of lightweight construction, heat insulation, lighting or fuel efficiency).

- ⁷ S. Kolb, A. Kessler, J. Lambauer: „Auswirkungen der Nanotechnologie auf die Energiewirtschaft“, *Energiewirtschaftliche Tagesfragen*, vol.57, issue 3, 2007
- ⁸ T. Harper: “Energy And Nanotechnologies: A Rational Market Based Analysis”, presentation at the impulse event NanoEnergie, June 28, 2007, Hanau

Application fields of fuel cells broken down by performance range, years until widespread commercial distribution is achieved and by turnover and substitution potential (sources: VDI-VDE, VDI TZ GmbH, Allied Business Intelligence Inc.)

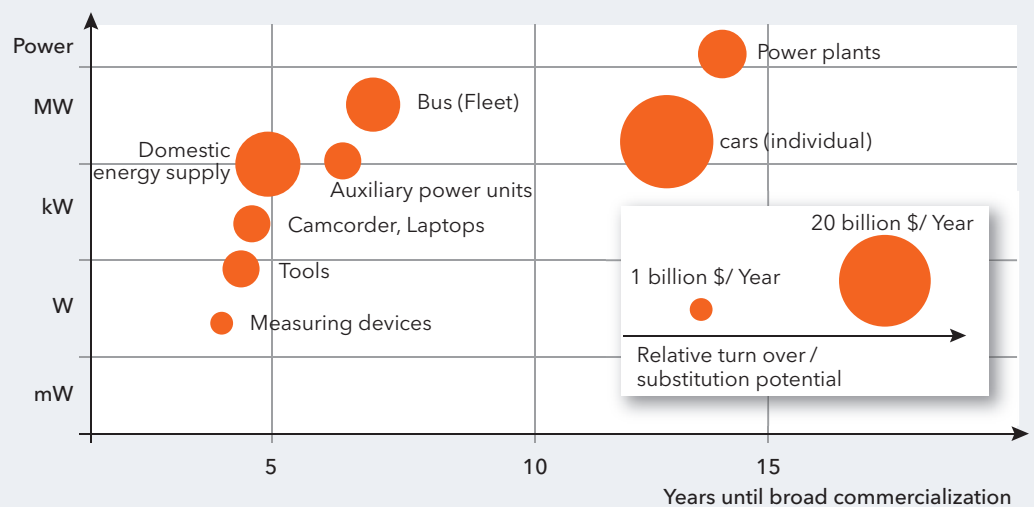

3 Application Potentials of Nanotechnology

3.1 More Efficient Energy Development

Nanotechnologies provide potentials to achieve efficiency increases and cost savings in a number of application fields of energy development, particularly in the generation of renewables, through optimized materials and components.

Solar Cells

The application of nanotechnologies is regarded as a key factor for photovoltaics to achieve broad economic acceptance through considerable cost savings and increases in efficiency based on new materials and solar cell types as well as simpler production processes. With the help of nanostructures, such as quantum dots, it is possible to optimally adjust band gaps of semiconductors to the incident radiation spectrum or to emit several charge carriers per photon to thus improve conversion efficiencies. This applies also to improved light entrapment, e.g. by avoidance of reflection losses at the front cover through nanostructured anti-reflection layers or even through up or down conversion of light wave lengths through special nanostructures, which could enable better utilization of the radiated light spectrum. Furthermore, new material combinations such as polymeric semiconductors are used, which provide low conversion efficiency, but could be produced considerably more economically in future, due to cheap mass production methods. The application of nanotechnological process technology, as for example plasma-aided procedures and the design of surfaces and layer structures on the nanolevel, enables the optimization of cell structures and efficiencies of all solar cell types.

Thin-Layer Solar Cells

In contrast to the silicon wafer technology, thin-layer solar cells provide potentials for cost reductions in the manufacturing of solar cells due to material savings, low-temperature processes, integrated cell insulation and a high automation level in series production. A further advantage is the fact that flexible substrates are used and thus new application fields such as the integration into textiles are being developed. Apart from silicon, material combinations of copper/indium/gallium/sulphur/selenium (CIGS-cells) as well as III-V semiconductors (e.g. gallium arsenide) are applied, which allow efficiencies of up to 20%. For further optimization, inter alia nanotexturized transparent conductive oxide layers are analyzed as front electrodes, which shall help optimize light dispersion in the substrate and minimize reflection losses. Further approaches lie in the improvement of the rear reflectors for which usually metal layers (e.g. silver) are used, for example through the application of photonic crystals or non-metal nanolayer systems to further increase the light yield in the substrate.

Electron-microscopic photo (left) and schematic structure (right) of a cadmium telluride thin-layer solar cell (source: TU Darmstadt)

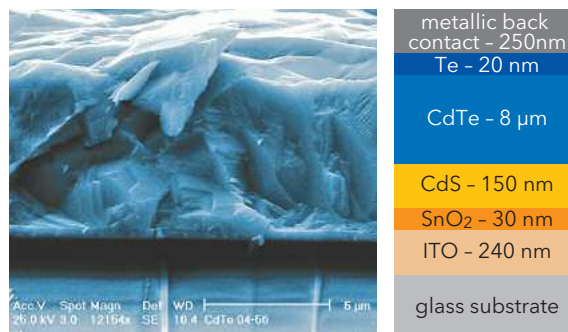

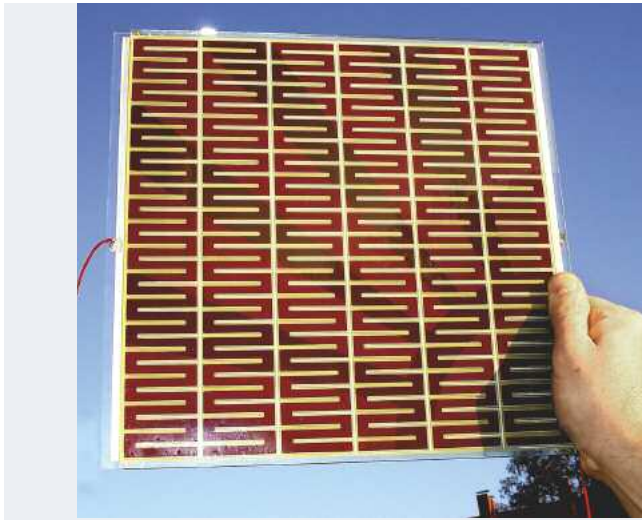

Prototype of a dye solar cell module for decorative applications in glass facades (source: FHG ISE)

Titanium Dioxide Nanoparticles in Dye Solar Cells

Dye solar cells use titanium dioxide nanoparticles doped with dye molecules (e.g. different ruthenium complexes) for charge separation. The absorption of light results in the emission of electrons in the dye molecules, which are absorbed by the titanium dioxide particles and transferred to the electrode via a redox electrolyte. The dye molecules are again regenerated in the electrolyte by an iodide/triiodide redox couple. Advantages of dye solar cells are cheap manufacturing processes through screen printing, application possibilities even at diffuse incidence of light (e.g. for internal application) as well as the transparency and color design possibilities of the cells, which open up interesting architectural application perspectives. What is disadvantageous is that, in case of leakages, the applied chemically-reactive liquid electrolytes can reach the environment and show relatively low efficiencies of below 10%. First applications of prototypes have been implemented e.g. by the Fraunhofer Institute for Solar Energy Systems.

Fullerene Derivates as Electron Acceptors in Polymer Solar Cells

Polymer solar cells use organic semiconductors for energy conversion. Conjugated polymers are used as light-absorbing electron-donors, while fullerene derivatives are used as electron acceptors. Both substances are integrated into the sandwich-like cell structure between charge-transport layers and electrodes (ITO, metals) as 100 to 300 nm thin composite layers. Advantages of such cells are low-cost materials and manufacturing processes as well as their mechanical flexibility. Mass production of large-scale modules in a continuous roll-to-roll-printing process is aspired. The optimization of materials and cell structure should bring about medium-term efficiencies of approx. 10% and a lifespan of several years. New research approaches concern the replacement of ITO-layers for transparent polymer composites. Apart from cost savings, this also provides the possibility to increase light trapping through imprinting nanostructures. The extensive periodical surface structures produced through holographic exposure processes can be transferred into the polymer layer of the solar cells in a low-cost imprinting process. In Germany, research on polymer solar cells is boosted by a research alliance of the Federal Government and industry partners, inter alia, the company Merck (cf. p. 66).

Principle structure and functional principle of an organic solar cell. The photoactive layer consists of a composite of semi-conductive polymers (red) and fullerenes (blue) acting as donor/acceptor pair for photovoltaic charge separation (source: ZAE Bayern).

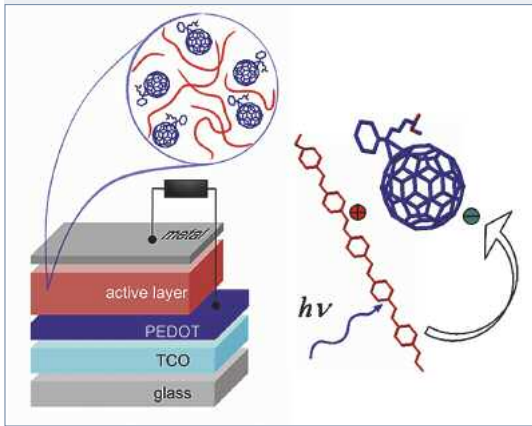

ITO-free, unencapsulated organic solar cell on flexible substrate (FHG-ISE)



Nanolayers in Stack Cells

The vertical arrangement of two or more material systems with different band gaps helps optimize the energy yield of solar cells. With approx. 40%, stack cells of III/V-semiconductor systems show the highest conversion efficiencies of all solar cell types. Such solar cells are currently mainly applied in aerospace industry, since due to costly manufacturing processes the cells are too expensive for terrestrial applications. Application will become more efficient, when sunlight is concentrated through relatively inexpensive optics, and the efficiency of the cells is thus increased. Such concentrator modules are already commercially available, and there are prospects for a reduction of costs through further system optimizations and economies of scales in production from currently approx. 6 € per Wp (Watt Peak, installed capacity at optimum sun incidence) to approx. 1.5 € per Wp, so that this kind of power generation will quite be competitive against grid prices in the long run. Stack cells are also feasible on the basis of other material systems, such as silicon or polymers.

Solar power plant in Australia where compound semiconductor solar cells with optical concentrators are used (source: SolarSystems).



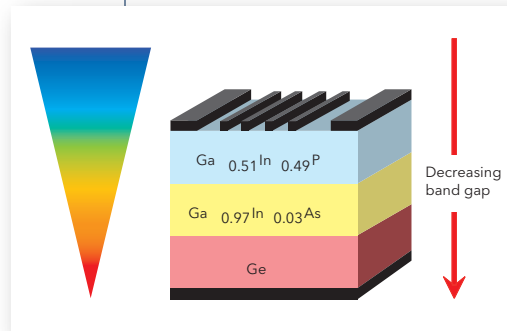
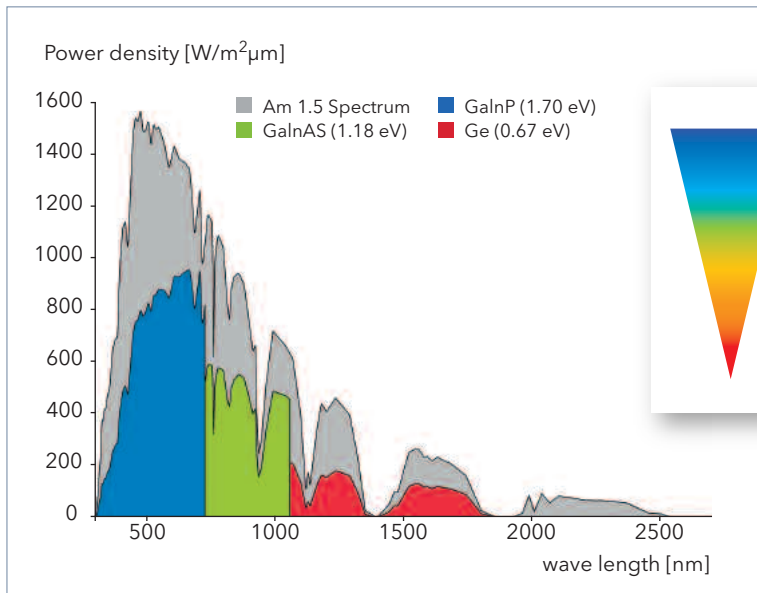

Absorption spectra of semiconductor materials used in stack solar cells for the optimization of the quantum yield. Stack cells consist of a layer sequence of compound semiconductors with different band gaps (source: FHG-ISE).

Quantum Dots for Solar Cells

Quantum dots are nanoscale clusters of semiconductor compounds with extraordinary optoelectronic properties, which are modifiable due to quantum physical effects in dependence of the cluster size. Applications in solar cells are interesting, since on the one hand, several electron-hole pairs per photon can be produced by quantum dots, on the other hand, the absorption bands can be optimally adjusted to the wavelengths of the irradiating light.

On the laboratory scale, three-dimensional grids of quantum dots or even other structures like nanowires are possible which would be interesting for the application in solar cells. With such cells, conversion efficiencies of over 60% are theoretically feasible. However, the current state of research is still far from this, and up to now it has not been possible to experimentally show a functioning model of a quantum dot solar cell.

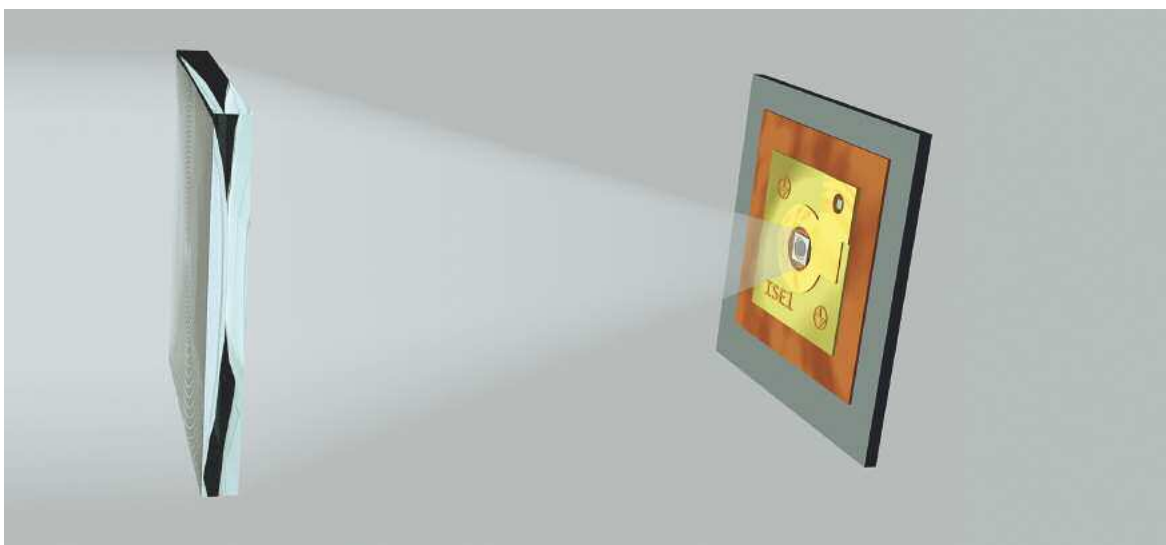

Stack cells of III/V semiconductors are usually operated by optical concentrators, which concentrate light on the solar cell to increase efficiency (sources: FHG-ISE).

Nanostructured Antireflection Layers

A relatively low-cost method of increasing energy yields of solar cells and solar collectors is the application of antireflection layers. Marketable developments are antireflection layers for flat glass based on a nanoporous coating of silicon dioxide. The layers are made on the basis of a sol-gel process with ensuing dip coating. The porosity allows the adjustment of the effective refraction index between glass and ambient air, which helps reduce reflection losses of glass panes of usually 8% to 2%. Thus it is possible to increase the annual heat yield of solar collectors by up to ten percent.



Antireflection coating
(source: Fraunhofer ISC)

Wind Energy

The transition to increasingly larger and more powerful wind generators observed in the last years leads to growing challenges regarding the mechanical load capacity of materials and components. The application of nanotechnologies could contribute much to fundamental solutions, for example through the use of composite materials based on carbon nanotubes for lightweight and high-strength rotor blades. Nanostructuring processes could enable the utilization of biomimetic effects borrowed from nature, which counteract the development of eddies at rotor vanes and thus reduce the noise level of wind generators and optimize energy input.

CNT-composites could also contribute to the protection against damages from lightning strikes which are responsible for more than 10% of the failures of wind generators. Not only do they dispose of promising mechanical features, but they also provide excellent electric conductivity. In the field of polymer composites, a CNT-content of approx. 1% is enough to generate a continuous network of carbon nanotubes, which ensures high electric conductivity of the polymer composite. Such materials provide also potentials for the electromagnetic shielding of the control electronics of wind generators. Nanoscale hard coatings are applied for wear protection of gears and bearings (cf. section Combustion Engines).

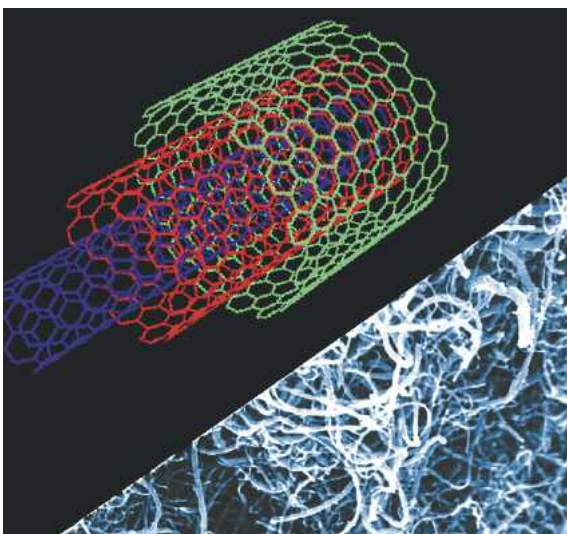

High-strength and electrically conductive CNT-composites could be applied in rotor blades of wind generators (source: BMS, Siemens)



Fossil Fuel Recovery

Nanomaterials play also a role in the recovery of fossil fuels. Suspensions of nanoparticulate natural silicates, for example, are used in oil production for viscosity control. Nanoporous and nanoparticulate materials enable the separation of contaminations in oil deposits and thus an increase in the production yield. The optimization of the mechanical wear resistance of drill probes for the development of oil and gas deposits in deep earth layers is also possible. In future, even unconventional sources like oil shale will have to be increasingly utilized for the recovery of

crude oil. However, oil extraction from such sources requires improved technologies, just like sensorics for the exploration of storage sites, which could benefit from nanotechnological innovations. In the USA, the consortium "nano for energy" has recently been constituted in cooperation with major oil companies like BP, Shell, and ConocoPhillips, which will develop the application of nanotechnologies for the improvement of oil and gas production with an annual budget of several billion dollars.

3.2 Efficient Energy Conversion

Nano-Optimized Fuel Cells

Nanotechnologies provide optimization potentials for all standard fuel cell systems, namely regarding optimized electrodes, membranes, electrolytes or even catalysts in the electrodes as well as for hydrogen production.

In the field of solid fuel cells of the SOFC-type, for example, ion-conductivity can be enhanced through the application of ceramic nanopowder on the basis of yttrium-stabilized zirconium.

In the case of membrane fuel cells, mainly polymer membranes are concerned, the temperature stability of which shall be improved, inter alia, through the application of inorganic-organic nanocomposites. Here, the functionalized polymers used are modified with inorganic nanoparticles in sol-gel processes. Higher efficiencies are achieved through higher operating temperatures, and the sensitivity of the catalysts towards carbon monoxide arising from the reforming process when producing hydrogen from methanol, can be reduced. Furthermore, the nanostructuring of electrode material plays an important role to achieve highest possible efficiencies in the electrochemical hydrogen/oxygen conversion or in hydrogen production through the conversion of natural gas or methanol (in case of direct methanol fuel cells).

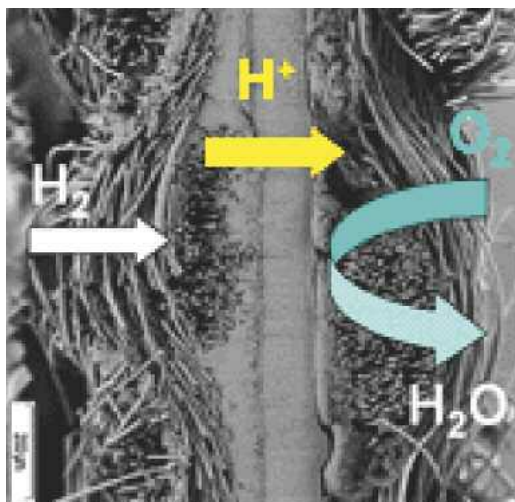

Membrane electrode unit of a polymer electrolyte membrane fuel cell. Hydrogen (H_2) is catalytically oxidized at the anode (left), and the arising protons (H^+) move through the polymer membrane (center) to the cathode (right), where, together with oxygen (O_2), they are converted to water molecules (source: Institute for Polymer Research, GKSS).

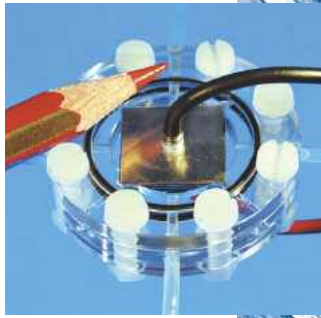

Micro fuel cell with a power density of 1 W/cm^3 , microstructured flow field (source: FHG ISE)

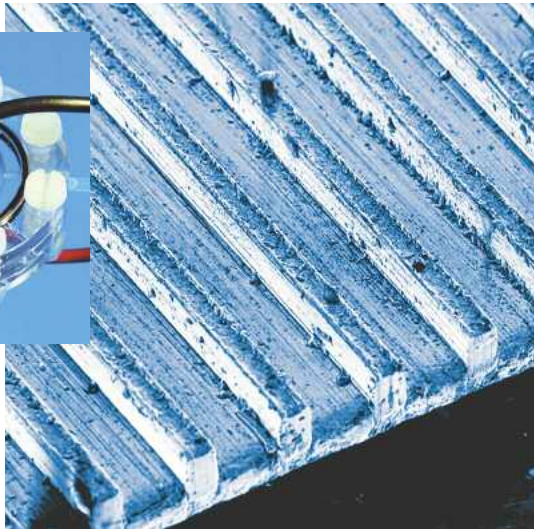

Moreover, nanostructuring is the key to enhance the activity of the electrode material and noble metal catalysts for the electrochemical conversion of hydrogen. Fullerenes, incorporated in electrode materials, increase efficiency in material conversion and enable material savings in the precious metal catalyst. A further interesting development is the micro fuel cell, particularly attractive for mobile applications. Due to the progress made in microsystems technology in the last years, the miniaturization of low-temperature fuel cells and the related mobile core components like pumps and fans could be continuously advanced.

Nanomaterials for Thermoelectric Energy Conversion

Nanostructured thermoelectrics are of great interest, since the electrical and thermal properties of the materials can be specifically influenced by the structure sizes. In future, the characterization of the relation of structure, composition and properties on the nanolevel will enable the design of materials with desired properties. Interesting are, for example, materials suitable for use in the high-temperature range of up to 1000°C , like cobaltates. Nanostructures analyzed in connection with thermoelectrics comprise, inter alia, nanostructured surfaces, quantum dots or quantum wires. "Super lattice" of BiTe or SbTe-quantum dots (quantum dot super-lattices) or even nanoscale substance classes like skutterudites have turned out to be high-efficient thermoelectrics. Skutterudites are a comprehensive class of substances based on the cobalt antimonide compound. New processes allow the production of nanoscale powder from such classes of substances with strongly increased portions of grain boundaries. Under certain circumstances, such grain boundaries have a more intense scattering effect on photons than on the electric charge carriers. Thus the ratio of electrical to thermal conductivity can be increased and, likewise, the quality of the thermoelectric material.

With thermoelectric generators, body heat - for example in the hand - can be converted into electric current (source: Fraunhofer IIS)

Crystal structure (left) and transmission electron microscopic picture (right) of a tailor-made perovskite-like thermoelectrically active cobaltate, a compound of lanthanum, cobalt and oxygen (source: Mikropelt)

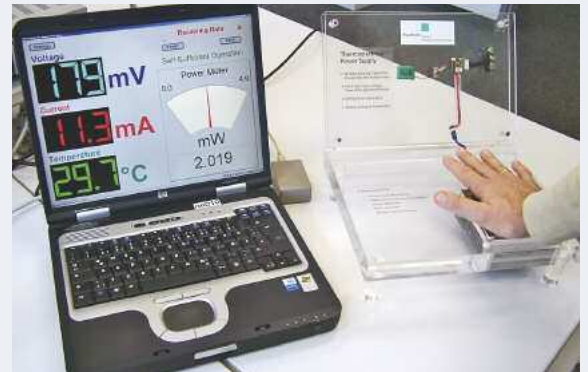
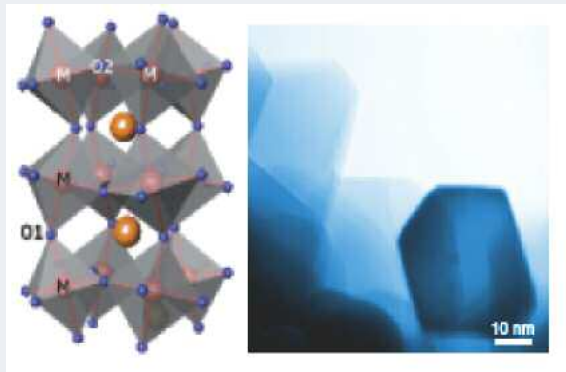

Efficient Processes for Hydrogen Production

To pave the way for hydrogen as a future energy carrier, efficient processes for hydrogen production are required. Nanostructuring helps increase efficiency of precious metal catalysts in the electrolytic decomposition of water. Further optimization potentials result from high-temperature electrolysis of water, with electrolysis taking place at about 1000 °C and high efficiencies of over 90 % are achieved in conversion. Here, ceramic materials are used as oxygen ion-conductive solid electrolytes, the ion conductivity and temperature resistance of which can be enhanced by the application of nanomaterials.

Photoelectrolytic water decomposition provides a further promising approach. In this case, the absorption of light at photoelectrodes leads to the photochemical decomposition of water in the photocell, with oxygen oxidizing at the anode and hydrogen atoms at the cathode being reduced to elemental hydrogen.

Important criteria for the selection of semiconductor materials for photoelectrodes are their stability in aqueous solutions as well as the conversion efficiency through band gaps optimally adjusted to the redox potentials of water. Stack cells of III/V semiconductors show promising conversion efficiency, however they are usually unstable in aqueous media and expensive in production. Currently, a hopeful alternative seems to be the application of low-cost metal oxides, e.g. of the elements titan, manganese, iron and tin as electrode material. Nanostructuring and the utilization of nanocrystalline substances provide starting points for further optimizations of the conversion efficiency which, at the moment, is still far from economical applicability.

Nanocatalysts for the Production of Hydrocarbon-Based Fuels

Nanomaterials like zeolite and nanostructured metal oxides have been applied for a long time on an industrial scale for the decomposition of long-chain hydrocarbons in crude oil refining. With growing scarcity of global oil reserves the far greater amount of coal will regain importance as a source for liquid fuels and chemical raw materials in future. Up to now, the known technical methods for coal liquefaction failed due to lacking economic efficiency. Improvements of methods, inter alia in the field of nanostructured catalysts, can help increase the efficiency of coal hydrogenation considerably. Interest in coal liquefaction is currently observed especially in China, where several pilot plants are going to be installed. A long-term development goal is the low-cost production of synthetic Diesel and fuel petrol from natural gas or biomass gasification using nanooptimized catalysts.

⁹ D. Ostermann :
„Hydrogen production through solar energy“,
Zeitschrift für Wasserstoff und Brennstoffzelle 08|06

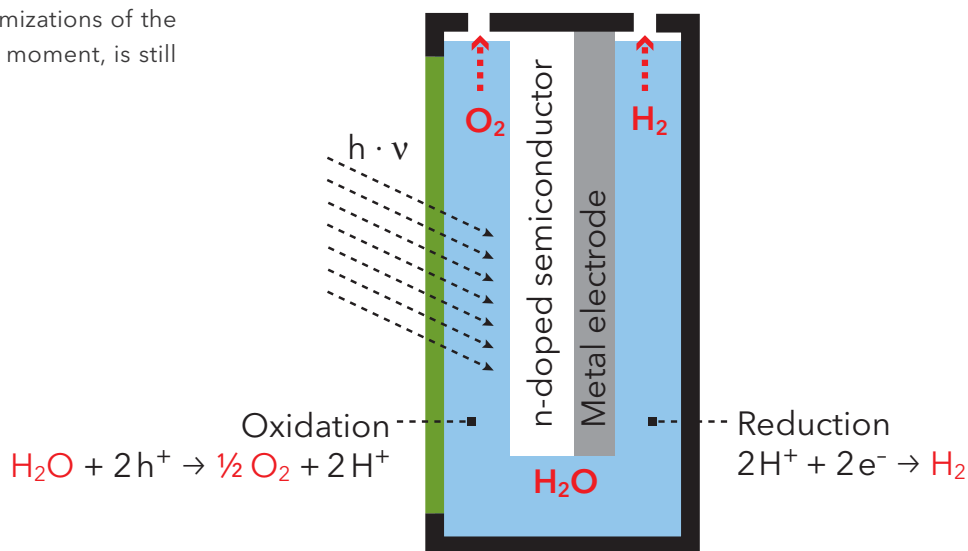

Schematic sketch of photoelectrolytic hydrogen production. Electron-hole pairs in semiconductors are produced through absorption of light energy. If the semiconductor is in contact with a metal counter electrode, photo voltage builds up resulting in the decomposition of the aqueous electrolytes in hydrogen and oxygen (source: ODB-Tec GmbH)⁹

Conventional Steam and Turbine Power Plants

Structure of thermal barrier layers produced by means of electron beam generated plasma decomposition (IFW Darmstadt)

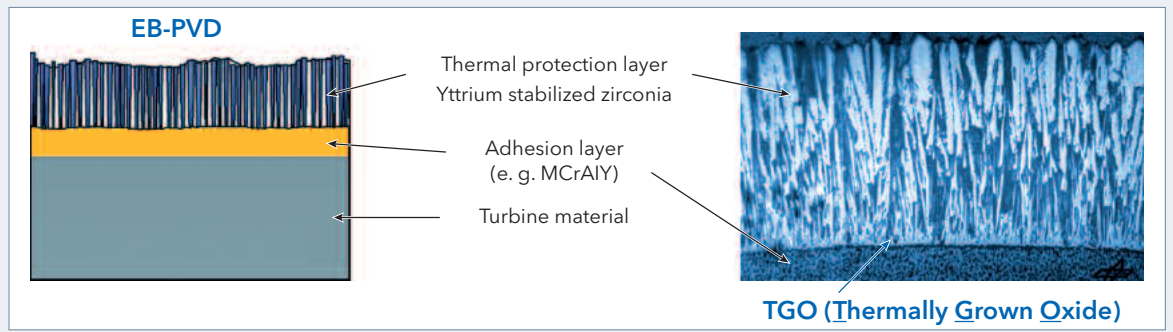

Nanostructured Thermal Barrier Layers for Gas Turbines

Thermal barrier layers are indispensable for heat protection of turbine blades in gas turbines, since with 1500°C the gas temperatures at the turbine inlet are significantly above the melting point of the turbine material. Essential demands on thermal barrier layers are low heat conductivity and thermal expansion adapted to the substrate to minimize tensions and crack formation in the material. Complex heat barrier systems can be produced through modern multiple-source plasma coating processes consisting of active, adhesive and barrier layers with nanoscale precision and various material combinations. This provides further optimization potentials, for example to reduce heat conductivity of layers, to increase durability of turbine components and thus to enable higher operating temperatures. Therefore, the efficiency of gas turbines could be further improved and considerable savings in costs and carbon dioxide emissions would be possible. According to calculations of the IFW Darmstadt, approx. 1 m € and 1500 g CO₂ could be saved each year through an increase in efficiency of 1% in 400 MW gas and steam turbine power plants.

Carbon Dioxide Separation through Nanostructured Membranes

The separation of carbon dioxide from the flue gas stream of coal-fired power plants and its storage in subsoil geological deposits is currently one of the technological developments for the realization of CO₂-neutral coal-fired power plants, which is intensively boosted.

Nanotechnologies could contribute to the development of processes for the selective separation of carbon dioxide through specific membranes. Approaches are provided, for example, by nanostructured polymer membranes coated with catalysts, which convert carbon dioxide into hydrogen carbonate in presence of water. The solid hydrogen carbonate can then be easily separated from the other flue gas components. Another possible approach refers to the development of ceramic nanotubes, which enable a very efficient separation of oxygen from air. If this pure oxygen was used for the combustion of fossil fuels, the resulting flue gas would be almost exclusively CO₂, which could be easily separated and utilized.

Left: Gas turbine (IFW Darmstadt)



Right: Nanostructured membranes play a key role in selective gas separation (source: Research Center Geesthacht)

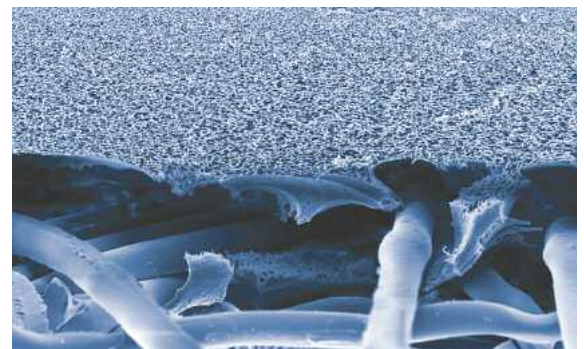



Adherences at the heat exchanger in power plants can be avoided through ceramic nanocoatings. Top: uncoated surface; bottom: with nanocoating (source: ItN Nanovation)

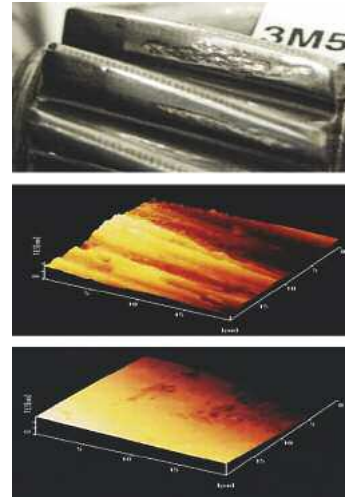

Top: wear damage of a gearwheel; Left: surface profile before and after treatment with nanoparticles (source: Rewitec)

Antiadhesive Layers for Boilers and Heat Exchangers in Coal-Fired Power Plants

A problem in the operation of coal-fired power plants or refuse incineration plants are cakings of combustion residues in the boiler area and in heat exchangers, which require regular and cost-intensive maintenance. Ceramic antiadhesive layers on the basis of nanoparticulate coating materials can considerably help reduce cakings, thus the operating life of heat exchanger tubes and maintenance intervals will be extended. Potentials for nanobased antiadhesive layers are also provided in other industrial processes, in which the encrustation of heat exchangers and the resulting reduced thermal energy transport are a problem.

Fuel Savings in Combustion Engines

Fuel consumption of car combustion engines is determined by engine friction to approx. 10-15%. The coating of movable engine components like cylinder, piston and valves with nanocrystalline composite materials helps reduce friction and wear and, thus, save fuel. Efficiency and precision of Diesel injectors can be optimized through nanocrystalline piezomaterials and nano-wear protection layers on the basis of DLC (diamond-like carbon) (see Automotive Nanotechnology, volume 3, series Aktionslinie Hessen-Nanotech).

The company Rewitec from Lahnuau developed an innovative coating technology applied to ceramize the surface of metal mechanical components in engines, gears etc. and thus to protect them against wear. Nanoparticles are added during operation and, due to the tribological contact developing at high pressures and temperatures, react with the metal surfaces forming hard ceramic compounds. Thus, the components are not only protected against wear, but existing mechanical damages can also be regenerated. Apart from the application in combustion engines, this process is also suitable for a number of mechanical components such as gears, bearings or pumps, and leads to significant energy savings and longer tool lives.

Another toehold for fuel savings is provided by nanoparticulate Diesel additives of cerioxide, which contribute to more efficient fuel combustion and the reduction of particulate emissions. Such nanoparticles are currently tested in practical field tests, in which fuel savings of up to 11 % could be verified. To date, however, little is known about possible side-effects caused by cerioxide particles reaching the environment.

3.3 Nanooptimized Energy Stores

Lithium-Ion Batteries

The lithium-ion technology is regarded to be a promising variant of energy storage due to high cell voltage and excellent energy and power density. Nanotechnologies will be able to further enhance the capacity and safety of lithium-ion batteries, in particular through optimized electrode materials and electrolytes. Here, development goals are anodes and cathodes with higher loading/discharge capacity, for example through nanoporous carbon materials (e.g. carbon aerogels, carbon nanotubes etc.). Higher energy densities can also be achieved through higher cell voltage, e.g. through cathodes of mixed oxides of the category LiMPO_4 with ($M = \text{Co, Ni, Mn}$). The substitution of organic liquid electrolytes for polymer electrolytes and the application of ceramic films on the basis of nanomaterials as separators help significantly improve the safety of lithium-ion batteries. Such films, mechanically flexible despite high stability, are being marketed by Evonik under the tradename of 'Separion'.

The practical suitability of such materials in hybrid-electric vehicles (HEV) was demonstrated by a test car, which, as the first hybrid car registered in Germany, has already covered a distance of 40,000 km since 2005. Through the application of carbon-coated nanoparticles for electrode materials, it is also possible to improve operating life and temperature stability of other battery types, such as lead or nickel-hydride accumulators.

Flexible ceramic membranes, enhancing temperature stability and thus safety of lithium-ion batteries, can be produced in a low-cost "roll-to-roll" process (source: Evonik).



Schematic sketch of carbon-aerogel-based supercapacitors. The large surface of the carbon clusters allows high charge density of the capacitors (source: ZAE).

Supercapacitors

Supercapacitors are electrochemical double-layer capacitors characterized by high energy and power density. They consist of two electrodes surrounded by an electrolyte and separated by a separator. Since the loading capacity depends on the electrode surface, a significant performance enhancement of supercapacitors will be achieved through nanostructuring and the associated surface extension. Carbon aerogels as nanoporous substances are perfectly suitable as graphitic electrode materials in supercapacitors due to their extremely high inner surface, adjustable pore distribution and pore diameters. Due to these electrode materials, supercapacitors with power densities of more than 10 kW/kg should be possible. Application fields are mobile applications, where high energy amounts have to be provided or taken up in a short period of time (e.g. in energy recovery when braking electric vehicles)

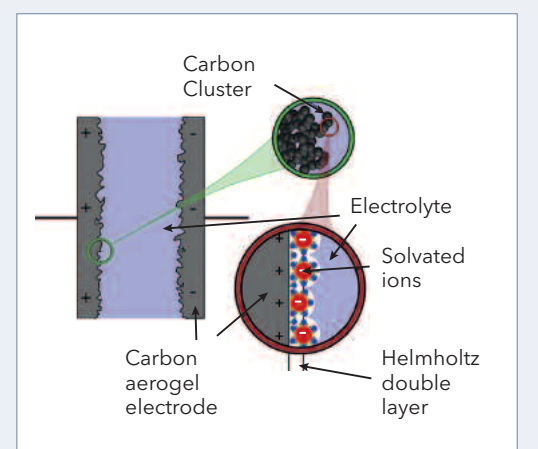

Electron-microscopic photo of a nanostructured carbon material. Right: nanostructured carbon films applied as electrode material in supercapacitors (source: ZAE)

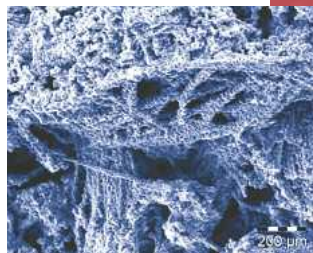

Hydrogen Storage

In the field of hydrogen storage, application possibilities of nanotechnologies are mainly found in the optimization of solid-state storage tanks, which reversibly bind hydrogen chemically or by adsorption in the storage material and release it again. Here, high-porosity materials seem to be promising, which are able to efficiently bind hydrogen in the pores through adsorption, or complex hydrides which store hydrogen chemically reversible in the lattice structure. Complex hydrides are salt-like compounds of hydrogen and light metal mixes, e.g. LiBH_4 , which contain gravimetric hydrogen densities of up to 20%. However, only a part of it can be used as reversible hydrogen store; moreover, the high temperatures required for hydrogen release are problematic. Further approaches are nanoporous metalorganic compounds, which dispose of very high surface values of approx. $3400 \text{ m}^2/\text{g}$. About two and a half gram of this compound corresponds to the surface of a football pitch. The currently achievable storage capacities, however, are quite far away from a possible application as hydrogen stores in cars. There are development potentials which seem to be economically tappable at least for the operation of fuel cells in mobile electronic devices. In general, however, there is great research demand in the development of solid-state storage tanks.

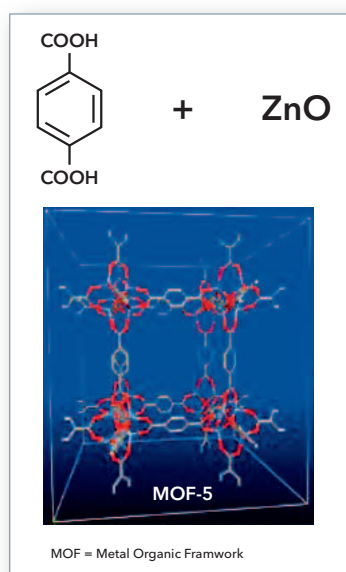

In future, hydrogen stores based on organometallic compounds could power micro fuel cells for portable electronics. The electron microscopic magnification clearly shows the nanoporous structure of these "nanocubes". Two and a half gram of this material has an inner surface corresponding to the surface of a football pitch (source: BASF).

In the research project, NANOSORB, promoted by the BMBF in cooperation with Merck and the University of Giessen, studies on relations of structure-properties for the interaction between gas and surface of different nanoporous material classes are carried out, among them metallorganic frameworks, organo zeolites and other organically modified silica compounds. With the application of molecular-modeling techniques, insights shall be gained in the optimization of pore sizes, geometries and topologies as well as the chemical composition of materials to be generated in future.

Furthermore, nanostructured materials like aerogels could also find application in cryo storage of liquid hydrogen due to their excellent thermal insulation effect. Energy and fuel losses are to be minimized through high-efficient insulation of liquefied gas tanks to improve efficiency in transport and storage of liquefied gases like hydrogen or natural gas.

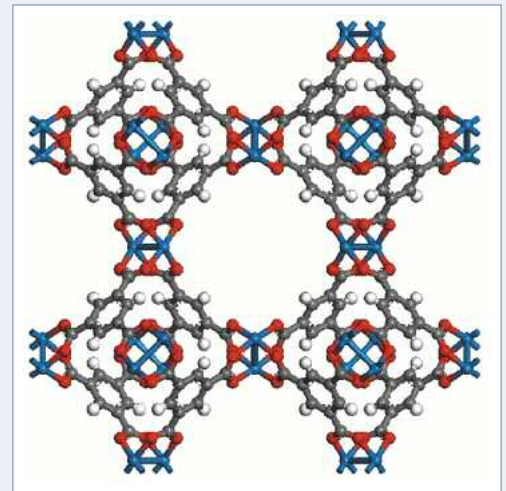

Unit cell of a metallorganic framework $\text{Cu}_3(\text{BTC})_2$. This compound shows two differently sized pore systems (diameter of approx. 0.9 resp. 1.1 nm) and has a very high storage capacity for gaseous hydrogen (source: university of Giessen).

3.4 Energy Transport through Low-Loss Power Supply and Smart Grids

Low-Loss Power Supply through Nanomaterials

Considerable progress was made in the development of high-temperature superconductors in the last years through the production of yttrium-barium copper oxide (YBCO) on metallic carriers (so-called Coated Conductors, CC), which significantly extended the processability and applicability of this material class. Cable lengths of over 600 m could already be realized. Superconductors will play a growing role in energy technology for low-loss wired power supply, in coil windings and bearings of electric engines as well as in residual current circuit breakers in high-voltage grids. The most important challenge is the production of all deposited layers (superconducting and buffer protection layers) by chemical means from low-cost precursor to decrease costs to an economically attractive value. Nanotechnologies provide footholds for the control of the microstructure in layer formation, for example through specific insertion of nanoparticles in the

form of particle inclusions in the lattice structure. Currently, superconductive nanostructured systems from sol-gel precursors are being developed in a project supported by the BMBF. In the long run, cables of carbon nanotube composites as high-efficient conductors could be an alternative for a low-loss power supply line in high-voltage grids. This, however, would require further significant progresses with regard to more efficient production methods and technologies for the production of long CNT-fibers with uniform structure.

Nanocrystalline Magnetically Soft Materials in Transformers

Nanocrystalline magnetically soft materials, for example, produced through quick solidification processes of iron-base alloys, are perfectly suitable for applications in energy technology, due to properties such as high permeability and temperature stability. Such materials are applied in low-loss transformers, electronic energy meters, residual current circuit breakers or also power-electronic components. The company Magnetec from Langenselbold (Hessen) is a global market leader in the commercialization of these nanocrystalline magnetic materials in the form of toroidal tape wound cores for various electrotechnical applications.

Nanostructured Insulation Materials for High-Voltage Power Lines

Efficiency of power transfer in high-voltage power lines increases with increasing amperage. In Europe, current is usually conducted at approx. 400 kV, while in extensive countries like China and India high-voltage grids with up to 1500 kV are aspired.

Due to increased voltages and the required current compaction as a result of the feeding of decentralized power generators and the supply of huge metropolitan areas, the electrical and mechanical strains on high-voltage power lines are growing. Hence, a central task of high-voltage technology is the further development of electric insulation systems, for example through the application of nanomaterials. The material design on the nanoscale enables the optimization of electric insulation properties like breakdown voltage, for example, through the application of nanostructured metal oxide powder in varistors as protection elements against overvoltages in power lines. Multifunctional, non-linear and auto-adaptive insulation systems are in development, the mechanical and electrical properties of which change with field strength, temperature or mechanical stress and adjust optimally to the power demand.



Nanocrystalline blank tape with a thickness of only 18 μm as basic material for optimized inductive components (source: Hitachi Metals Europe©)

Nanooptimized Power Electronics

The conversion and control of high-power currents through power-electronic components will gain further importance in future. Power electronics ensures low-loss power conversion on the way to the end user, it enables the power yield optimization of wind turbines through the adjustment of rotational speed to wind speed and plays a central role in the transfer of energy through longer sub-sea cables. Energy decentrally generated through photovoltaics can likewise only be used after power electronic conversion.

The further development of power semiconductors through materials with high bandgap, like silicon-carbide, will trigger an innovative boost and economically tap high-voltage (power grids or railway) or high temperature (e.g. in controls of car engine components) applications. The development of power electronics can benefit from nanotechnologies, for example through the optimization of the layer design of wide-bandgap semiconductors or even through the application of carbon nanotubes as cross-connection wires for high current flows at minimized heat development.

Smart Grids

The worldwide increasing liberalization of the electricity market will significantly increase the future demand on the flexibility of the power grids. Trans-European power trading requires efficient energy distribution even over long distances, a flexible adjustment to temporarily strongly fluctuating demands and a quick controllability of the power flow to limit the extent of grid failures and the risk of extensive blackouts. The existing power distribution grid encounters limits even regarding the growing decentral power supply from fluctuating renewable sources. The future power distribution requires grids which enable a dynamic load and failure management as well as a demand-driven energy supply with flexible price mechanisms.

Nanotechnologies could contribute essentially to the realization of this vision, for example through nanosensoric and power electronic components, which could cope with the extremely complex control and monitoring of such grids. Here, miniaturized magnetoresistive sensors on the basis of magnetic nanolayers provide potentials to enable an area-wide online-metering of current and voltage parameters in the grid.

The transfer of current requires a more efficient and flexible structure - nano-optimized components like e.g. conductive materials and insulators provide solution potentials (source: RWE)



3.5 Energy Saving Potentials through Nanotechnologies

In the short run, nanotechnologies will have the greatest effect on the avoidance of resource consumption and carbon dioxide emissions mainly in the field efficient energy use. Considerable energy saving potentials through nanotechnologically optimized products and production plants are to be found in nearly all branches of industry as well as in the private sector. A number of application examples in the respective industries (e.g. automotive, construction engineering, optics, production engineering) are provided in the brochure series of the Aktionslinie Hessen-Nanotech. Some examples regarding the most relevant fields of application are briefly described below.

Lighting Engineering

Nanotechnological applications in the field of lighting engineering first and foremost concern the development and use of energy efficient LED on the basis of inorganic and organic semiconductor materials. Due to the compact design, the variable color scheme and the high energy yield, the LED-technology has already tapped great market potentials in the illumination of displays, buildings and cars. The still poorly developed organic light-emitting diodes provide the potential for extensive lighting surfaces and screens on flexible substrates which allow the integration into many fields of interior equipment. Nanotechnological approaches arise, for instance, for the further optimization of LED through quantum dots which help improve energy efficiency and light yield. Furthermore, nanoscale light emitting particles contribute to the minimization of scattering effects of LED, and thus to the enhancement of the light yield. The particles need to be coated in order to increase particle stability.

The further development of OLED will also depend on nanotechnological innovations, which concern, inter alia, the optimization of the field carrier materials, succession and thickness of layers, application of dopants and the purity of the materials used (see practical example, Merck).

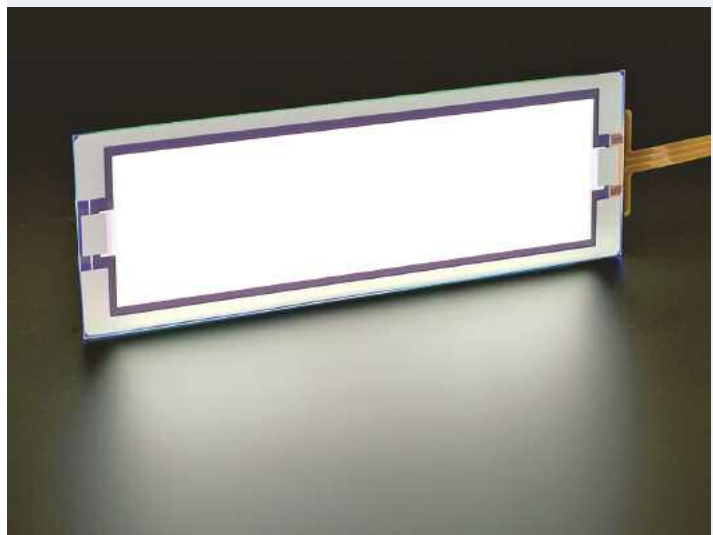

Organic light-emitting diodes (OLED)
(source: Merck KGaA, Darmstadt)

Nanoporous polymer foams (right, in electron-microscopic enlargement) provide a great potential for high-efficient heat barrier materials (source: BASF).

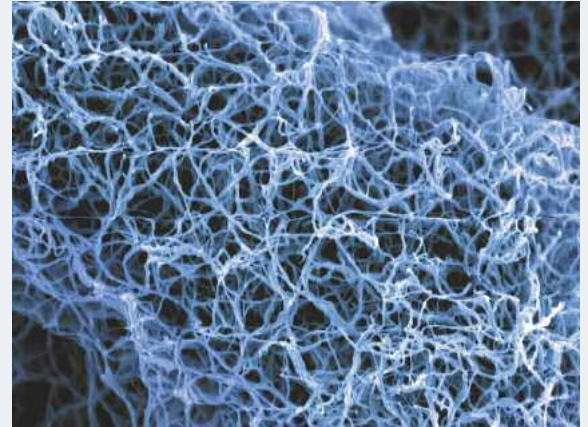
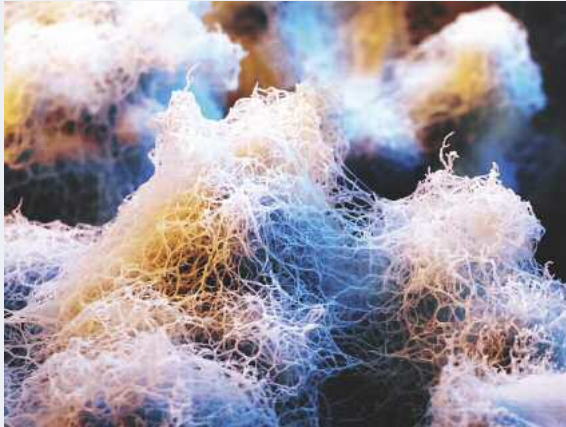

Thermal Insulation through Nanoporous Materials

The power demand for heating and cooling purposes in industrial fields and of private consumers has a considerable share in the total energy consumption worldwide. Here, great savings potentials result from the energetic reconstruction of old buildings, which account for approx. 80 % of the total building stock in Germany and require more than twice the heating energy allowed according to the applicable Heat Insulation Ordinance for new buildings. However, also insulation in technical processes, e.g. in the transport of liquid gases, is of great importance. Due to a pore size in the range of the average free path length of the gas molecules, nanoporous materials provide potentials for high-efficient insulation materials. Examples for such materials are aerogels which consist to 99 % of pore volumes in a network of nanoparticles, for instance of silicon dioxide, and are thus extremely lightweight. Despite relatively high manufacturing costs, first pilot projects are being realized for heat-insulated outside facades of aerogel materials (cf. volume 7, Uses for Nanotechnology in Architecture and Civil Engineering). Nanoporous polymer foams provide further development potential, even though their manufacturing is not yet economically advantageous. The cell size

of these nanocellular foams shall be reduced to such an extent that they correspond to the average free path length of a gas molecule. Hence, heat exchange as a consequence of the collision of gas molecules would cease almost completely. The resulting foams would show heat insulation properties similar to those of vacuum panels without the application of vacuum. In this way, the insulation effect of foam could be enhanced by more than 50 % and the required material thickness for a given insulation capacity could be reduced by more than the half. The work on this concept is currently still in a state of basic research. Commercial products will therefore not be available in the medium run. A solution approach could be the polymerization of organic monomers with the help of structure-templates, which enable the predetermination of structure and pore size of the foam.

Carbon aerogels for high-temperature insulations (up to 3000 °C) (source: ZAE)

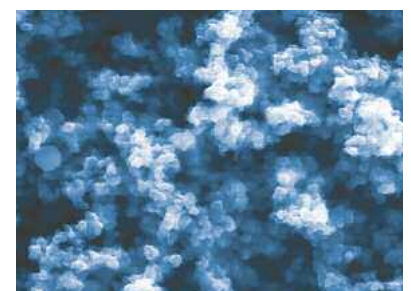

Energy Efficiency of Production Processes

Technical processes in industry, in particular in basic chemistry or metal production, often involve high application of energy and contribute extensively to the operating costs. The energy saving potential through the application of nanotechnologies is mainly found in the substitution or optimization of energy-intensive reaction steps, for example through nanostructured catalysts or thermal insulation materials. More than 80% of all products of the chemical industry are made via catalysis. Due to an increased active surface area, nanostructured catalysts enable higher reaction yields or partly even new, energetically more favorable ways of synthesis. Here, the application of fullerenes may be mentioned as a catalyst in the industrially relevant styrene synthesis, which allows a significant increase in reaction yields and a reduction of the process temperature.

In the manufacturing of ceramics, nanoscale powders can help reduce sintering temperatures and thus save energy. Microreaction technology, i.e. the control of chemical processes in miniaturized reactors with optimized heat and matter exchange provides further approaches. The highly-parallel application of microreactors enables the production of chemicals partly requiring significantly lower energy input than in large-scale industrial plants.

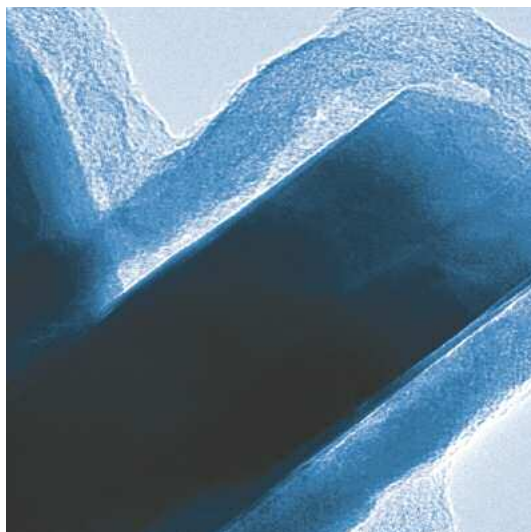

Iron-oxide catalyst enclosed by fullerene-like carbon layers (Fe_2O_3) for the optimization of styrene synthesis (source: Fritz-Haber-Institute)

Lightweight Construction through Nanocomposites

High-stability lightweight construction materials can contribute to considerable savings, in particular in the transport sector. Nanomaterials offer various potentials to achieve savings in weight and to combine different material properties, such as

- extremely high strength-weight ratios,
- increased hardness, viscosity and wear resistance,
- improved thermal capacity and corrosion resistance.

Potentials for lightweight construction measures are provided, for example, by nanostructured metal-matrix composites (MMC) or even polymeric nanocomposites. Due to their temperature stability, strength and low density, metal-matrix composites (MMC), just like fiber-reinforced titan and aluminum alloys, have a high application potential for structures, especially in aerospace industry. Through the nanoscale structure of the MMC, higher strength and resistance against material fatigue can be achieved as well as a better formability compared to conventional MMC. Nanobased protection coatings will extend the applicability of magnesium alloys in car manufacture. In contrast to conventional chrome coatings, more environmentally friendly coatings based on silicon dioxide able to be produced through plasma or sol-gel processes, provide better abrasion and corrosion protection for magnesium materials. Also polymer composites reinforced with carbon nanotubes have the potential for ultralight high-stability construction materials. For practical application, however, a number of technical problems regarding the orientation and integration into the polymer matrix have to be solved and further cost reductions in the material manufacturing have to be achieved.

4 Practical Examples from Hessen

4.1 Ceramic Thermal Barrier Coating Systems for Turbine Blades

Electron microscopic photo of a thermal barrier coating consisting of a top coat rich in aluminum oxide (TGO, Thermally Grown Oxide) and a thermal barrier coating TBC

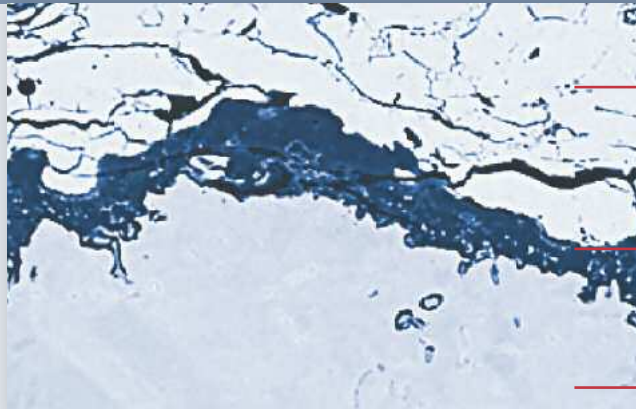

TBC

TGO

Turbine material

Today, gas turbine blades of aircraft and industrial turbines are increasingly coated with ceramic thermal barrier coatings, for example, of partly stabilized zirconium oxide. With the application of thermal barrier coating systems in connection with efficient blade cooling, the gas inlet temperature of aircraft and industrial turbines can be raised to a level impossible to reach with unprotected turbine blades. Thermal barrier coating systems as a design element enable therefore, on the one hand, an improvement of efficiency, on the other hand the reduction of environmental stress.

Thermal barrier coating systems consist of base material, adhesion promoting layer and thermal barrier coating (TBC). Due to start-up and shut-down processes as well as capacity changes of gas turbines and the related temperature gradients and transients, the thermal barrier coating system is exposed to thermomechanical alternating stress. The base material of the blade bears the mechanical stress.

The ceramic thermal barrier coating serves as thermal resistance and thus controls the heat flow into the base material. The adhesion promoting layer serves the connection to the thermal barrier coating, balances the different thermal expansion coefficients of thermal barrier coating and base material and serves as oxidation protection for the base material. In today's systems, this occurs through the formation of an Al_2O_3 -rich top layer (TGO, Thermally Grown Oxide), which develops to a third layer between thermal barrier coating and metal. Here, an aluminum-rich phase in the adhesion promoting layer serves as aluminum reservoir which helps maintain the aluminum activity in the layer matrix required for

the top-layer formation over a long operation period. While the blade base material allows application of the metal adhesion promoting layer by LLPS (Low Pressure Plasma Spraying), the thermal barrier coating is applied through atmospheric plasma spraying (APS-process) or through electron beam physical vapor deposition (EB-PVD).

The influence of the surface structure of the adhesion promoting layer on the lifespan of ceramic thermal barrier coatings is the subject of current surveys on crack formation up to delamination, accompanied by the development of suitable test methods and life assessment concepts. The research work is boosted by the Federal Institute for Materials Research and Testing (MPA), Darmstadt, and the Institute for Materials Technology (IfW) of the TU Darmstadt, which together, form a powerful technical-scientific center with internationally proven capacity in materials testing and research.

CONTACT

Staatliche Materialprüfungsanstalt MPA
Subject Field: Materials Research
Technische Universität Darmstadt

Prof. Dr.-Ing. Christina Berger
Dr.-Ing. Alfred Scholz

Grafenstrasse 2, D-64283 Darmstadt, Germany
Phone +49 (0)6151 16-2151, Fax -6118
www.tu-darmstadt.de/mpa-ifw



4.2 Nanostructured Catalysts for Efficient Membrane Fuel Cells

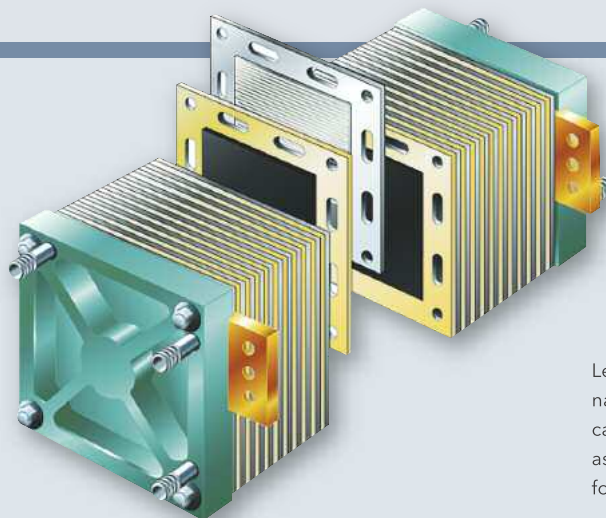
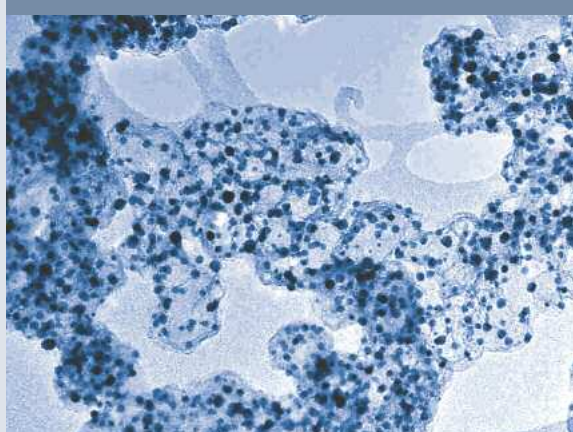

Left: Platinum nanoparticles on carbon black carrier as electro-catalysts for fuel cells

Right: Schematic structure of a membrane-electrode-unit

The Umicore AG & Co. KG is the worldwide leader in the manufacturing of automotive exhaust gas catalysts and a number of precious metal-containing products. In many cases, such products contribute decisively to more environmentally friendly processes or to the reduction of their energy consumption. One of the research priorities is the membrane fuel cell (PEMFC, Proton Exchange Membrane Fuel Cell), which is regarded as an environmentally friendly and high-efficient energy conversion technique. Nitrogen oxides or other pollutants, as they occur in conventional combustion, do not arise in PEMFC.

The application is planned and has already been successfully demonstrated in cars, domestic energy supply plants and even in portable energy supply (laptop and mobile phones). Umicore and the joint-venture SolviCore develop and produce catalysts and so-called membrane-electrode units as key components for this new technology.

Decisive for the application of the catalysts in membrane fuel cells is the nanofine distribution of the precious metal and a good fixation on the catalyst support. Thus, a better catalytic effect per gram of precious metal is achieved and a contribution is made to the saving of resources and the reduction of costs.

Umicore is an international material technology group located in Brussels. The company with a turnover of 9 billion € and 18,000 employees operates in more than 75 countries of the world. The activities are focused on the business fields of Advanced Materials, Precious Metals Products and Catalysts, Precious Metals Services and Zinc Specialties.

The Group is represented in Hessen by the Umicore AG & Co. KG in the Hanau-Wolfgang Industrial Park. There, approx. 1,100 persons are employed in the business units Automotive Catalysts, Precious Metals Chemistry, Precious Metals Services, Electronic Materials, Platinum Engineered Materials and Electrotechnical Materials



CONTACT

Umicore AG & CO KG

Dr. Ralf Zuber
ralf.zuber@eu.umicore.com

POB 1351, D-63403 Hanau, Germany
Phone: +49 (0)6181 59-2556, Fax -72556
www.umicore.de

4.3 New Materials for Photovoltaics

Solar energy will account for an essential part of future power supply. Both in the Science-to-Business-Center of Creavis Technologies & Innovation and in the Project House of Functional Films & Surfaces, research in the solar field is being carried out. Creavis is developing new photovoltaic materials and related technologies for the application in low-cost, flexible solar cells. Nanostructured materials have different properties than the materials used so far. This applies, for example, to the light-absorption important for photovoltaics. Moreover, nanodispersions are printable, which may facilitate the manufacturing of solar cells. If it is managed to replace silicon wafers required today by thin, printable photovoltaic layers, the production of mechanically flexible solar cells in high-productivity roll-to-roll manufacturing process will be possible. With nanostructured materials, efficiencies can be increased from today 20 % to over 50 % in future. The cost goal for such photovoltaic systems is 1 Euro per installed Watt.

Schematic structure (graphic) and prototype of a flexible polymer solar cell (photo top right)

Processability of Nanomaterials

High productivity possible through printing processes

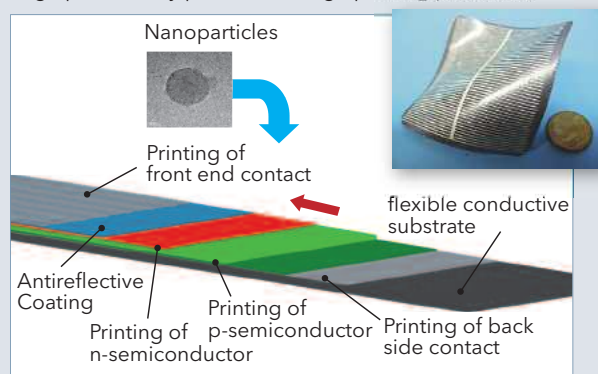

Nevertheless, the material has to be available at a realistic price to significantly reduce the manufacturing costs of flexible solar cells. In the field of barrier films, the project-house researchers intend to develop a barrier film on the basis of already existing Evonik materials, which unites all properties of materials previously consisting of several layers. There are several possibilities conceivable to achieve this. From a nanotechnological point of view, the functionalization of surfaces is of special importance. Here, Evonik can fall back on known in-house technologies as well as on the results of previous project houses. The intelligent combination of processes and materials shall be realized in cooperation with external partners.

Schematic depiction of the roll-to-roll manufacturing process of thin-film solar cells

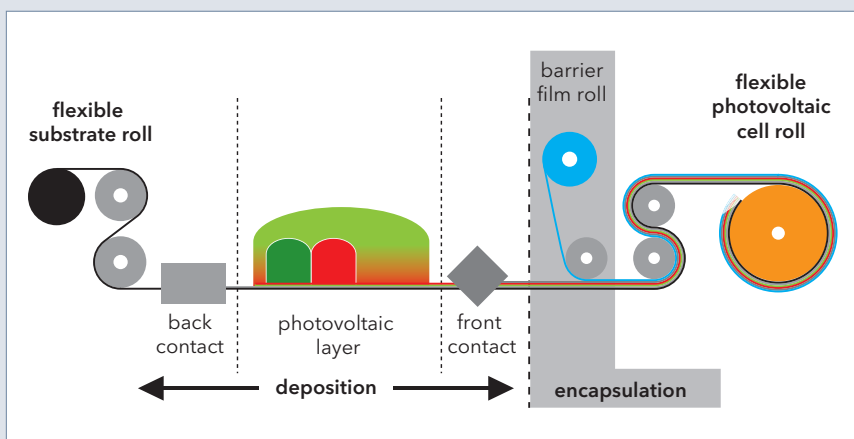

CONTACT



Evonik Industries AG
Project House Functional Films & Surfaces
Creavis Technologies & Innovation

Dr. Jochen Ackermann
jochen.ackermann@evonik.com

Rodenbacher Chaussee 4
D-63457 Hanau-Wolfgang, Germany
Phone +49 (0)6181 59-6375, Fax -2391
Mobile phone +49 (0)179 7828333
www.evonik.com

4.4 Nanotechnology for More Efficient Thermoelectric Energy Conversion

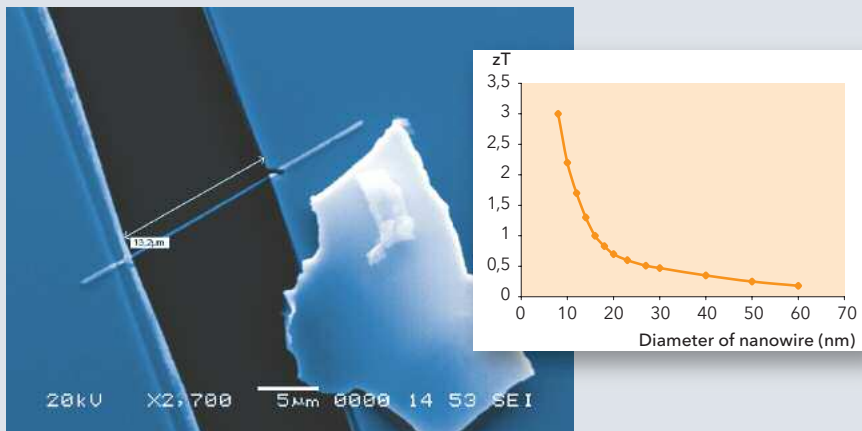

Calculated thermoelectric efficiency zT for Bi-nanowires (acc. to L.Yu-Ming et. al., Appl. Phys. Lett. 81 (2002), 2403 and bismuth nanowire (Manufactured by GSI Darmstadt, Material Research Division) with electric contacts for the measuring of thermoelectric properties (IMtech)

Thermoelectric converters convert heat directly into electricity. Examples for thermoelectric energy converters are thermogenerators and thermoelectric sensors. Up to now, p- and n-doped semiconductors with carrier concentrations in the range of $10^{19}/\text{cm}^3$ have been used as materials. The efficiency of energy conversion depends to a large extent on the thermoelectric figure of merit $z = \alpha^2\sigma/\lambda$ of the applied materials, which is determined by the Seebeck coefficient α , their electric conductivity σ and their thermal conductivity λ . Currently, the values achieved with most efficient thermoelectric bulk materials at different temperatures T exceed the "limit" $zT = 1$ only insignificantly. Thus, efficiency of thermoelectric generators usually remains below 10%.

Solid-state physical calculations for nanoscale thermoelectric materials show a significant potential to increase the thermoelectric figure of merit. In experiments, values of $zT > 2$ in multi-quantum-well-structures (MQW) could be verified. These are layer stacks of well layers of only few nanometers interleaved with similarly thin barrier layers (right figure). Load and heat transport in such MQW is "concentrated" (confinement) on the well-layer areas. Still larger increases in the thermoelectric figure of merit are to be expected when load and heat transport occur nearly one-dimensionally in nanowires.

The figure above shows the calculated zT -values for bismuth nanowires as a function of the wire diameter and the REM-picture of the Bi-nanowire prepared in a way to enable the experimental determination of its thermoelectric properties. Nanowires with high zT -values can be used both for energy conversion and the development of extremely sensitive thermoelectric sensors.

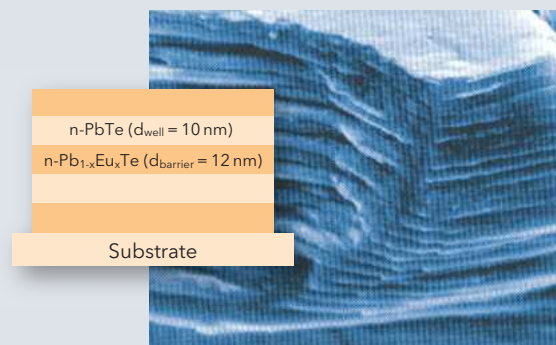

Schematic structure of von PbTe/PbEuTe multi-quantum-well-structures with high thermoelectric efficiency and REM-photo of a MQW structure of thermoelectric PbTe-well-layers interleaved with barrier layers (manufactured through molecular beam epitaxy; FhG-IPM Freiburg)

CONTACT

Fachhochschule Wiesbaden
 Institute for Microtechnologies (IMtech)
 Prof. Dr. F. Völklein, voelklein@physik.fh-wiesbaden.de
 Am Brückweg 26, D-65428 Rüsselsheim, Germany

Gesellschaft für Schwerionenforschung mbH,
 Darmstadt, Material Research Division
 Dr. Th. Cornelius, Th.Cornelius@gsi.de
 Planckstrasse 1, D-64291 Darmstadt, Germany



4.5 High-Efficiency and Compact Energy Conversion with Nanocrystalline Toroidal Tape Wound Cores

Current-compensated radio interference suppression chokes on the basis of nanocrystalline NANOPERM®-materials. The components cushion grid-bound interferences in power grids.

Electron microscopic photo of a nanocrystalline softmagnetic iron alloy (source: Hitachi Metals Europe©)

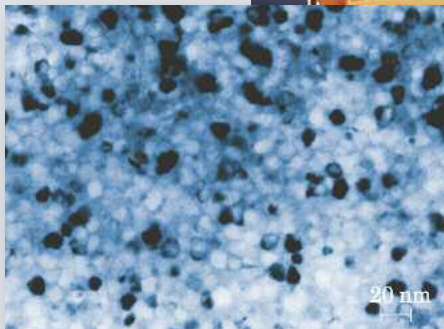

Background right: Nanocrystalline raw tape with a thickness of only 18 µm as base material for optimized inductive components (source: Hitachi Metals Europe©)

Front right: NANOPERM® provides the optimization of a wide range of inductive components.



In the development and processing of renewable forms of energy, such as in wind and solar energy engineering,

process efficiency is of utmost importance to enable the end user to use this precious commodity to the largest possible extent resp. to achieve optimum feed-in tariffs. Thus only the most powerful components are increasingly used in electronic circuits for energy conversion, since in these fields of application "investments in high quality" will pay off very quickly.

The MAGNETEC GmbH has been manufacturing high-quality inductive components for industrial application for almost 25 years. Approx. 8 years ago, they started the production of toroidal tape wound cores of the new nanocrystal material NANOPERM®. This softmagnetic material, initially available in the form of 20 mm tapes, has an amorphous inner structure and is magnetically neutral. Special magnetic properties, almost unimaginable ten years ago, are permanently imprinted through a particularly designed heat treatment under inert protective gas and with precisely adjustable magnetic fields. This enables not only the smaller design of e.g. magnetic cores, chokes and transformers, but also the operation at high switching frequencies (typically 100 kHz).

Hence, the efficiency of devices and plants increases significantly while dimensions and weight are reduced at the same time. Furthermore, the application of NANOPERM® is focused on the field of installation engineering (RCD), general electromagnetic compatibility (EMC-filter) and modern electronic energy meters.

Due to the technical superiority of renewable energies, more and more users decide in favor of these new components with nanocrystalline toroidal tape wound cores from MAGNETEC, which meanwhile employ a staff of more than 400. In spring 2007, the company was given the Innovation Award of the "Initiative Mittelstand". Worldwide, there are less than 10 companies producing such components.



CONTACT

MAGNETEC GmbH

Dr. Martin Ferch
mferch@magnetec.de

Industriestrasse 7
D-63505 Langenselbold, Germany
Phone +49 (0)6184 9202-27, Fax -20
www.magnetec.de

MAGNETEC®
MAGNET - TECHNOLOGIE

4.6 Nanostructured High-Temperature Superconductors for Low-Loss Power Transmission

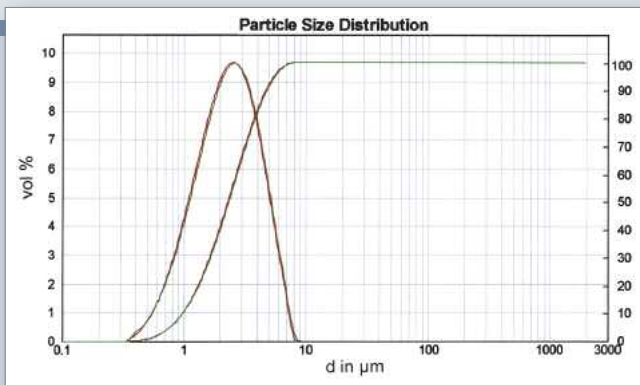

Particle size distribution of a ceramic base powder

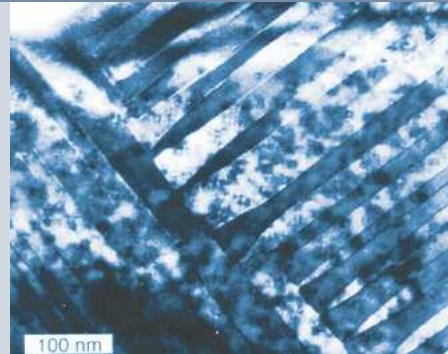

Twin domain boundaries with characteristically deformed twin lamellae. Densely distributed Y_2O_3 -inclusions of 5 nm are to be recognized.

Increased energy costs and the need for environmental responsibility compel careful and efficient handling of resources, in particular in energy engineering. In electric energy engineering, this future challenge is confronted by the application of cryo and low-loss high-temperature superconductors (HTS) in systems like e.g. engines/generators, transformers, current limiters, power transmission cables and energy stores.

The HTS are high-tech materials based on oxide ceramic which is processed to achieve technically applicable conductors. HTS show the macroscopic quantum effect of "superconduction" through the utilization and control of the material on the nanoscale.

Different methods are used for the manufacturing of HTS, ranging from flat wire manufacturing of a tube filled with powder up to thin-layer coating techniques. Both chemical and physical methods are applied. All processes have in common that the generation of nanoscale structures is required, which guarantees homogeneity over a length scale of kilometers.

At the beginning of the wire manufacturing from pipes, the ceramics are present in the form of powder. This powder consists of both "coarser" particles (grain sizes approx. $> 2\mu m$) and a portion of nano-sized particles of approx. 10 percent (Fig. top left). The nano-portion is the key to quality and capacity of the material, since in sintering, it joins the coarse grains in such a manner that their ampacity turns into a macroscopically usable property.

Thus, the correlation on the atomic level is decisive for the quality and ampacity of the material. The ampacity of the HTS is increased in particular through the fact that nanoscale trapping centers prevent areas filled with magnetic flux (quantized vortices) from moving (Fig. bottom right). Otherwise, the movement of this area would require energy loss. Depending on the chosen manufacturing methods, e.g. precipitations or twin domains (see Fig. top right) are used for the generation of trapping centers or twin domains to prevent the lossy movement of the quantized vortices. Thus, so-called nanodots, i.e. foreign phases like yttrium oxide (Y_2O_3) on the nanometer scale (approx. 35 nm generated or added in fine-dispersive form) can retain the quantized vortices and contribute to a capacity enhancement of the HTS.

Schematic depiction of a quantized vortex

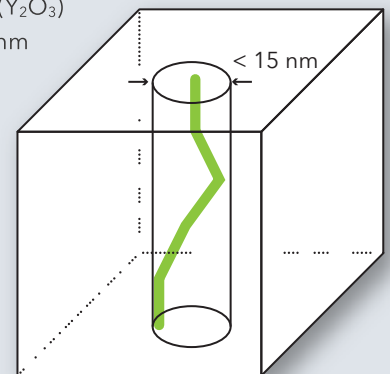

CONTACT

European High Temperature Superconductors GmbH & Co. KG

Reinhard Dietrich
info@bruker-ehs.com

Ehrichstrasse 10, D-63450 Hanau, Germany
Phone +49 (0)6181 4384-4062, Fax -4453
www.bruker-ehs.com



4.7 High-Efficiency Heating Devices for Heat Supply of Buildings Based on Nanoporous Materials

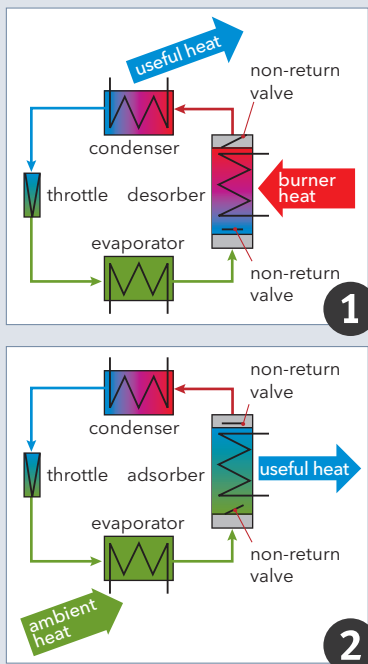

Principle depiction of a periodically working adsorption heat pump

Efforts made to avoid or reduce CO₂-emissions on the one hand, and the sharp price increase in fossil fuels on the other hand promise high growth rates for the application of resource-saving heating devices in future. Due to this market development, Viessmann is developing a gas-driven zeolite heating device as an innovative contribution to an increase in energy conversion efficiency and emission reduction for the heating of detached and semi-detached houses. Here, it is a combination of a zeolite-water adsorption heat pump and a gas condensing boiler. The goal of the adsorption heat pump is the supply of useful heat at a higher temperature level by adding low-temperature heat to the work process. The work process is based on the fact that, at a

given temperature, the vapor pressure of the coolant reduces with increasing concentration of the adsorbent. This enables the coolant to evaporate, e.g. through the supply of ambient heat, at a low temperature level and to be adsorbed at the temperature at which the useful heat shall be supplied.

A multicomponent mixture is used as working substance, which, in the Viessmann development, consists of a two-substance system in which water acts as the volatile coolant and zeolite as the solid sorbent. Zeolites are crystalline, hydrated aluminosilicates with nanoporous framework structure. The adsorption properties of zeolites are based on the large inner surface of 800 to 1100 m²/g as well as on the high electrostatic adsorption forces releasing a high degree of adsorption heat, especially in case of polar molecules such as water or ammonia. Therefore, zeolites exhibit a great potential for energy conversion processes with clearly higher efficiency.

In principle, an adsorption heat pump consists of a sorber heat exchanger equipped with two non-return valves working as desorber or adsorber, depending on the operating phase. It includes the conventional components of a heat pump, i.e. condenser, throttle and evaporator. In the desorption phase (Fig. 1), heat of a gas burner is used to dry the zeolite. The water bound to the zeolite is being expelled. This causes the pressure in the desorber

chamber to rise, which results in the closing of the non-return valve towards the evaporator and its opening towards the condenser. The expelled water vapor flows into the condenser and emits liquefaction energy as useful energy to the heating grid. This sub-process continuous until the zeolite has reached its maximum process temperature.

At the end of the desorption phase, the sorber heat exchanger is hydraulically changed to enable the heat transfer medium of the heating grid to flow through. Thus pressure and temperature in the sorber chamber decrease, which results in the closing of the upper non-return valve. As soon as the pressure in the sorber chamber has fallen below the pressure of the evaporator chamber, the lower valve will open and connect the evaporator chamber with the sorber chamber (Fig. 2). The pressure of the coolant liquefied in the condenser is decreased in the throttle so that the coolant evaporates in the evaporator under the absorption of ambient heat. The coolant vapor then flows in the sorber heat exchanger, now acting as adsorber, and is there bound by the zeolite. The adsorption heat released here (total of condensation and latent heat of the water vapor in the zeolite structures) is dissipated to the heating circuit in the form of useful heat. Due to the additional supply of ambient heat to the process, efficiencies of up to 135 % referring to the heating value can be achieved, which clearly outperform conventional condensing boilers with a maximum efficiency of 111 %. This corresponds to a reduction in CO₂-emission of 20 % compared to the state-of-the-art in gas heating of detached and semi-detached houses.

VISSMANN

CONTACT

Viessmann Werke GmbH & Co. KG

Dr.-Ing. Belal Dawoud

DrDaw@viessmann.com

Viessmann Strasse 1

D-35107 Allendorf / Eder, Germany

Phone +49 (0)6452 70-3410, Fax -6410

4.8 Nanocoatings for the Sealing of Metal Surfaces



The picture shows the wear-protection coating of a camshaft. The strongest coating occurs in the area exposed to the highest pressure at the highest point of the cam.

The company REWITEC from Lahnau deals with wear-protection layers and tribological properties of metal components. REWITEC has succeeded in developing a nanocoating, which reconditions metal surfaces worn during operation and provides lasting protection against wear and abrasion. These nanocoatings offer protection for combustion engines, gear boxes, compressors and bearings of all kinds, even under extreme conditions. The REWITEC coating technology is based on the modification of the surface structure of grinding metal parts and the generation of a new nanosmooth metal silicate layer with a surface roughness in the range of few nanometers.

The active components of the REWITEC active ingredient consist of a mixture of different synthesized silicate compounds. They react with the metal surfaces due to the high temperatures and pressures developing in the friction area. Thus a metal-silicate/metal-silicate friction pair with improved tribological properties develops from the original metal-metal friction pair. In practice, the REWITEC active ingredient is added to the original lubricant which transfers it to the friction areas. After a few operating hours it is completely converted without influencing or changing the properties of the lubricant.

The grain size of the particles contained in the REWITEC active ingredient is ranging from few nanometers to some micrometers. However, with regard to the formulation of ready-to-use lubricants, REWITEC is increasingly dealing with the application of pure nanoparticles. At granting the Innovation Award for the German Economy 2008, REWITEC got the final for their innovative nanocoatings for tribological systems.

Application Fields

The REWITEC nanocoating is applied in tribological systems consisting of grinding metal surfaces. It extends service life and increases efficiency and reliability of machines and appliances. Due to the significant reduction of the CO-HC- and NO_x-emission and Diesel exhaust particulates in combustion engines, it contributes much to environmental protection. REWITEC nanocoating has already been successfully used in the following applications:



The pictures show two worm gears after dry-running operation. After continuous operation for 15 minutes, the surface of the left untreated gearwheel shows very strong scoring damage. The gearwheel previously treated with REWITEC does not show any signs of wear.



Wheel treads of ball bearing inner rings after 50 hours of continuous operation in the fatigue area. The left ball bearing has been operated with a special bearing lubricant. Wear is noticed. The wheel tread clearly shows pitting formation. The right ball bearing has been operated with the same special bearing lubricant added with REWITEC. There is no wear visible. A wear protection layer has developed on the wheel tread.

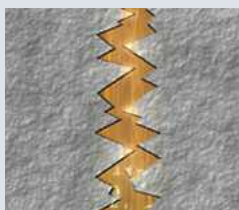

Schematic depiction of the REWITEC coating process:

1. Frictions in engines and gear boxes cause the development of high surface temperatures which trigger the chemical reaction process of the REWITEC concentrate.
2. The soft silicate particles do not only clean the grinding metal surfaces, they gradually form a wear-resistant metal silicate surface.
3. This new surface significantly enhances the original metal with regard to wear and abrasion.

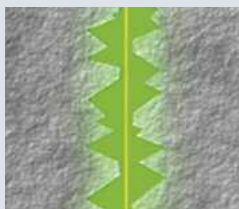
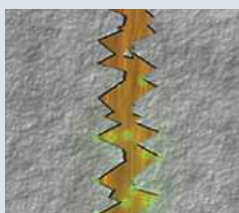

- Industrial facilities (gear boxes of all kinds, generators and combined heat and power plants, combustion engines, compressors, ball bearings and slide bearing, hydraulic systems, presses and die cutters, tool and printing machines, chain conveyors, gear rods and bevel wheels)
- Ships (main motors (2-stroke, 4-stroke), auxiliary diesel, main gearbox, winch transmission, crane and helm gearbox, separators, compressors, ball bearings and slide bearings)
- Commercial vehicles, passenger cars and trains (gasoline and Diesel driven engines, gearboxes, rear axles and differentials, hinges and hinge shafts, compressors, ball bearings and slide bearings) wind power plants (gear boxes, ball bearings and slide bearings)

CONTACT

REWITEC GmbH

Felix Altenheimer
f.altenheimer@rewitec.com

Dr.-Hans-Wilhelmi-Weg 1
D-35633 Lahnau, Germany
Phone +49 (0)6441 44599-0, Fax -25
Mobile phone +49 (0)173 6848570
www.rewitec.com



4.9 OLED-Materials from Darmstadt Illuminate the World

The roots of the Merck KGaA trace back to the year 1668. Hence, it is the oldest pharmaceutical-chemical company in the world.

In the last years, Merck invested a lot in OLED-technology which is treated as the next display generation. OLED means "Organic Light Emitting Diode" and describes the phenomenon that thin layers of semiconducting organic materials are capable of emitting light under application of an electric field (electro luminescence). The chemical structure of the emitter determines the color, while the size of the luminous surfaces varies over several orders of magnitude. These novel displays convince by their extraordinary color brilliance in connection with short circuit times and therefore find high acceptance among the viewers.

The application of OLED in products with high-resolution displays has already been repeatedly realized. Merck belongs to the global leaders in research, manufacturing and development of high-purity materials for the application in organic light-emitting diodes. In recent time, the possibility of using the ultra-flat OLED-components for lighting purposes, apart from their use in OLED-displays, has attracted increasing interest. For the first time, the OLED-technology allows the manufacturing of a high-efficiency flat luminous source with continuously adjustable brightness, which offers any possible shade of color and which can be less than 1 mm thick. However, in addition to the mere performance data of the OLED, other component characteristics play a decisive role especially for the designers. The diffuse and thus glare-free light emission of the lighting surface allows the realization of new kinds of illumination concepts. The shining roof interior in the car and the illuminated wall at home are only two examples for it. During the last two years, prototypes of ambient lighting, which delighted visitors at several fairs with its charm, were developed in cooperation with the designers Hannes Wettstein and Ingo Maurer. Apart from a table lamp, a glass table top equipped with illuminated tiles and a flexible ceiling lighting were presented.

The OLED-structure is generally characterized by layers with inclusions of nanometer-thin films between two electrodes, which induce the emission of light due to impressed voltage. Brightness is easily adjustable by adjusting the voltage in the range of 3 to 8 Volts. Depending on the component manufacturer, so-called "small molecules" are used as materials in the thin layers, which are evaporated in high vacuum, or long-chain molecules (polymers) which allow the use of solvent-based application from the liquid phase.

The potential of OLED-technology firmly in sight, science and industry agree that, here, a revolutionary technology is ripening.

The pronounced goal of Merck KGaA is keeping the development and production of innovative OLED-materials in Germany, analogous to the liquid crystal business, thus establishing a future core business. Organic semiconductors also play a key role in organic photovoltaics.

Merck use their know-how in the research initiative Organic Photovoltaics launched by the Federal Government and German industrial enterprises.



OLED-lighting fixtures
(source: Merck KGaA,
Darmstadt)

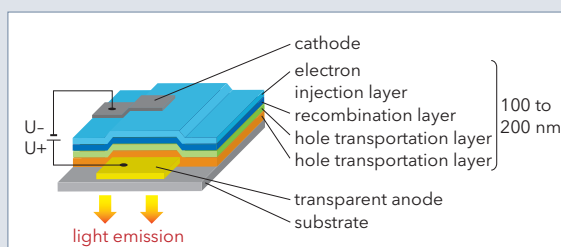

Schematic structure
of an OLED
(source: Merck)

CONTACT

Merck KGaA
D-64271 Darmstadt, Germany
Phone +49 (0)6151 72-0
www.merck4displays.com



4.10 Nanotechnology in Energy Research - TUD Energy Center

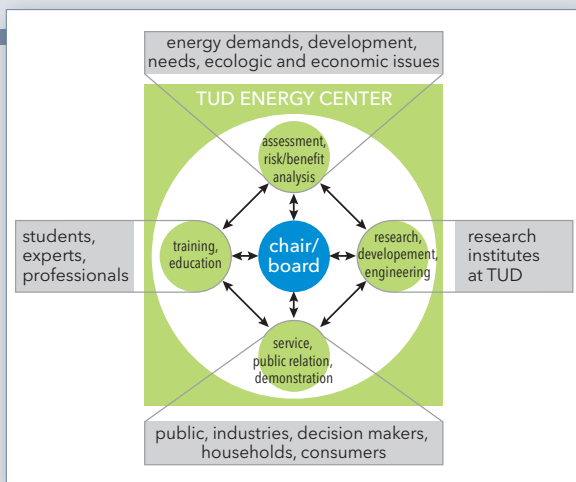

Task profile of the Energy Center of the TU Darmstadt

"Renewable Energy Technologies". The aim of the Energy Center of the Technical University of Darmstadt is the establishment of a scientific basis for the continuous transition from carbon-based non-renewable energy sources dominant today, to renewable and environmentally friendly energy carriers on all technology levels (primary energy sources, energy converters, energy stores and transport), both interdisciplinarily and transdisciplinarily. For this purpose, the acknowledged, however uncoordinated research and expertise in the different faculties of the TU Darmstadt are collated to contribute to the development of sustained energy technologies through training, research, chance assessment and service. The institutionalized cooperation of universities, industry, government and public is an integral part of the concept to come up to the various interrelations between energy and environmental matters, but also to the technological, economical and social implications of a sustainable energy future.

Many innovative energy systems rely on nanotechnology. Examples of research topics of the TUD, in which new materials and material combinations on the nanometer scale are used for the development of novel energy systems, are:

- Optimization of thin film solar cells for a low-cost direct power generation from sunlight. With inorganic absorber materials, the efficiency is determined by the structure and the electronic properties of homogeneous and heterogeneous phase limits in subnanolayers - up to the micrometer range. In two-dimensional and three-dimensional hybrid and composite materials of organic/inorganic semiconductors the transport of the charge carriers has to be controlled in the nanometer range.

A sustained and economically competitive energy management is based on a changing energy mix of various energy sources with "classic energy technologies" of constantly increasing efficiency and integrated

- Enhanced energy stores like Li-ion-batteries are produced through percolation structures from electronically conductive carbon nanotubes with active lithium storing and discharging nanocrystallites.
- Novel gas stores arise from nanometer-pores containing metalorganic networks.
- Catalysts for the conversion of biomass or electrocatalysts for fuel cells consist of metal nanoparticles on porous or graphitic substrates.
- Ceramic nanometer-thick protection layers serve the enhancement of temperature stability of turbine materials and thus their efficiency increase. Due to various regeneration processes, the respective desired function properties, based on synthesis and processing methods to be developed, have to be researched, characterized and optimized before the desired components and systems for application can be specifically developed.

The required research and development chains range from atomistic natural-scientific fundamentals up to the engineering-based realization including social-scientific implications. The TU Darmstadt Energy Center pursues this holistic approach.



CONTACT

TU Darmstadt Energy Center
Material Research

Prof. Dr. Wolfram Jaegermann
jaegerw@surface.tu-darmstadt.de
FB Material- und Geowissenschaften

Petersenstrasse 23
D-64287 Darmstadt, Germany
Phone +49 (0)6151 16-6304, Fax -6308
www.tu-darmstadt.de/fb/ms/fg/ofl/index.tud
www.energycenter.tu-darmstadt.de

5 Research Programs, Financing and Funding Possibilities

5.1 European Research Projects and Networks Relating to the Subject of Nanotechnologies and Energy

Demonstration of SOFC stack technology for operation at 600°C

Coordination: CENTRE NATIONAL DE LA RECHERCHE SCIENTIFIQUE (F)
EU FP6: Integrated Project, Duration until 2/2010

Non-noble catalysts for proton exchange membrane fuel cell anodes

Coordination: TU Munich (D)
EU FP6: Specific Targeted Research Project, Duration until 1/2010

Advanced Thin Film Technologies for Cost Effective Photovoltaics

Coordination: Hahn-Meitner-Institute (D)
EU FP6: Integrated Project, Duration until 1/2010

Ionic liquid based Lithium batteries

Coordination: TU Graz (A)
EU FP6: Specific Targeted Research Project, Duration until 12/2009

New Materials for Extreme Environments

Coordination: MPI IPP Munich (D)
EU FP6: Integrated Project, Duration until 11/2009

Nanotechnology for advanced rechargeable polymer lithium batteries

Coordination: VARTA EU
EU FP6: Specific Targeted Research Project, Duration until 9/2009

Nano engineered Titania thin films for advanced materials applications

Coordination: University of Cambridge (UK)
EU FP6: Specific Targeted Research Project, Duration until 9/2009

Processes and materials to synthesize knowledge-based ultra-performance nanostructured PVD thin films on gamma titanium aluminides

Coordination: DLR (D)
EU FP6: Integrated Project, Duration until 4/2009

Advanced lithium energy storage systems based on the use of nano-powders and nano-composite electrodes / electrolytes

Coordination: CENTRE NATIONAL DE LA RECHERCHE SCIENTIFIQUE (F)
EU FP6: Network of Excellence, Duration until 12/2008

A new wave making more efficient use of the solar spectrum (Full Spectrum)

Coordination: University of Madrid (E)
EU FP6: Integrated Project, Duration until 11/2008

Roll-to-roll technology for the production of high-efficiency low cost thin-film silicon photovoltaic modules

Coordination: University of Neuchatel (CH)
EU FP6: Specific Targeted Research Project, Duration until 10/2008

Proton Exchange Membrane-based Electrochemical Hydrogen Generator

Coordination: UNIVERSITE PARIS-SUD
EU FP6: Specific Targeted Research Project, Duration until 9/2008

Nanocrystalline silicon films for photovoltaic and optoelectronic applications

Coordination: University of Milan (I)
EU FP6: Specific Targeted Research Project, Duration until 5/2008

Design of highly conductive solid thin film electrolyte for stack integration within optical and energy storage applications

Coordination: HEF (F)
EU FP6: Network of Excellence, Duration until 3/2008

Selection of current or recently completed EU-research projects (more detailed information in the internet <http://cordis.europa.eu/fp6/projects.htm>).

5.2 National Research Projects and Networks Relating to the Subject of Nanotechnologies and Energies

Selection of current or recently completed BMBF-research initiatives and projects (more detailed information in the internet: <http://oas2.ip.kp.dlr.de/foekat/foekat>).

Calls and Initiatives Regarding BMBF-Funding Programs

Research Initiative "Organic Photovoltaics"

Joint technology initiative of the BMBF and BASF, Bosch, Merck and Schott, BMBF-funding volume approx. 60 m € (www.bmbf.de/de/10413.php)

High-performance materials for more energy efficiency and CO₂-savings: Performance leaps in energetic conversion processes

(www.bmbf.de/foerderungen/10484.php)

Next generation solar energy technology

Within the scope of the funding program "Basic Research Energy 2020+", Main focus on thin-layer solar cells, photo-induced hydrogen production (www.bmbf.de/foerderungen/10458.php)

Alliance for Innovation Li-ion battery "LIB 2015" for stationary and automotive applications

Funding volume approx. 60 m € (www.bmbf.de/foerderungen/11799.php)

BMBF-Projects

Development of new conjugated semiconductor materials for organic photovoltaics

BMBF-integrated project
Coordination: Merck KGaA

Nanoporous hybrid materials for mobile gas storage NanoSorb

BMBF-integrated project
Coordination: Merck KGaA

Resource-saving active materials for lithium-ion hybrid vehicle batteries (REALIBATT)

BMBF-integrated project
Coordination: Center for Solar Energy and Hydrogen Research (ZSW)

Concept and development of durable high-performance electrodes for fuel cells

BMBF-integrated project
Coordination: DaimlerChrysler AG

SiBNC-materials for manufacturing, energy and transport engineering (SIPEVe)

BMBF-integrated project
Coordination: Schunk Kohlenstofftechnik GmbH

Nanovolt - Optical nanostructures

BMBF-integrated project
Coordination: Martin-Luther-University Halle-Wittenberg

Nanotechnology in insulation system for innovative electric applications - Nanolso

BMBF-integrated project
Coordination: Siemens

Higher efficiencies of solar cells through optimized silicon processing - SolarFocus Project

BMBF-integrated project
Coordination: KoSolCo GmbH, Berlin
www.solarfocus.org

BMBF-Projects

Nanostructured metal-based ceramic membranes for gas-separation in fossil power plants (METPORE)

BMBF-Integrated project

Coordination: Forschungszentrum Jülich GmbH

LiBaMobil - New lithium-ion batteries for automotive applications with enhanced capacity and safety through nanotechnology

BMBF-Integrated project

Coordination: Evonik Degussa GmbH

SupraNanoSol - Superconductive nanostructured layer-systems from sol-gel precursors

BMBF-Integrated project

Coordination: Nexans Superconductors GmbH

NanoCap - Advanced Supercaps for automotive application based on nanostructured materials; Subproject BMW "Technology-driven development and technical integration"

BMBF-Integrated project

Coordination: Fraunhofer-Institute for silicate research

Charge carrier transport in silicon-based quantum structures for future high-performance solar cells

BMBF-Integrated project

Coordination: RWTH Aachen, Chair in and Institute for Semiconductor Technology

Further Research Initiatives at Federal Level

DFG-Project Group "Efficient Energy Conversion, Storage and Utilization"

Coordination: DFG, Bonn

DFG-Research Initiative Lithium High-Performance Batteries

Coordination: TU Graz

Information: www.dfg.de

BMW programs on energy research (partly relevant for the nanotechnology field)

Funding Focuses

- Modern Power Plant Technology
- Combined Heat and Power, District Heat
- Fuel Cell, Hydrogen
- Efficient Power Usage, Stores
- Energy-Optimized Construction
- Economic Energy Utilization in Industry, Business, Trade and Services

Information: <http://lexikon.bmwi.de/BMWi/Navigation/Energie/Energieforschung/foerderschwerpunkte.html>

BMU programs on energy research (partly relevant for the nanotechnology field)

Funding Focuses:

- Photovoltaics
- Low-Temperature Solarthermy
- Solar-Thermal Power Plants
- Wind Power
- Geothermy
- Water Power and Marine energy
- Grid Intergration and Optimization of Energy-Supply Systems

Information:

<http://www.erneuerbare-energien.de/inhalt/4595>

5.3 Funding Possibilities and Networks in Hessen

Aktionslinie Hessen-Nanotech

In 2005, the Hessian Ministry of Economy, Transport, Urban and Regional Development launched the Aktionslinie Hessen-Nanotech. The Aktionslinie Hessen concentrates and coordinates economy and technology-related activities in nanotechnologies and the material-based technologies throughout Hessen. Goal of the Aktionslinie is the national and international presentation of the Hessian competences in nanotechnologies and adjacent fields of technology like material and surface technology, microsystem technology and optical technologies. The international competitiveness and innovative strength of Hessian science and economy shall be boosted through technology and location marketing as well as through the support of networking. The Aktionslinie Hessen-Nanotech supports, in particular, the network of technology suppliers and users. Here the special focus is on the strongly developed application fields of automotive, chemistry, pharmaceuticals, biotechnology and medical technology, construction, environment and energy as well as on the information and communication technology. At the interfaces to nanosciences, the Aktionslinie Hessen-Nanotech cooperates with the NanoNetzwerkHessen. The project managing organization of the Aktionslinie Hessen-Nanotech is the Hessen Agentur.

Hessen

Nanotech

CONTACT

www.hessen-nanotech.de

- Hessisches Ministerium für Wirtschaft, Verkehr und Landesentwicklung
Sebastian Hummel
Kaiser-Friedrich-Ring 75
D-65185 Wiesbaden, Germany
Phone +49 (0)611 815-2471, Fax -2225
sebastian.hummel@hmwvl.hessen.de
- HA Hessen Agentur GmbH
Alexander Bracht
(Project Manager Hessen-Nanotech)
Markus Lämmer
Abraham-Lincoln-Strasse 38-42
D-65189 Wiesbaden, Germany
Phone +49 (0)611 774-8664, Fax -8620
markus.laemmer@hessen-agentur.de
www.hessen-agentur.de

Energy Location Hessen

Energy efficiency and the application of innovative energy technologies as well as the related resource saving are further core subjects of the Hessian Federal State Government, which have been embedded in the Hessian Ministry of Economy, Transport, Urban and Regional Development since April 2003. The Hessian Ministry of Economy is responsible for the fields of energy management, energy law, energy engineering and the support programs in the field of energy, except for the support of the energetic usage of biomass from agriculture and forestry, which is under the responsibility of the Hessian Ministry for Environment, Rural Development and Consumer Protection.

Priority is placed on the support of the field of rational energy use - i.e. energy saving. Apart from this, the Hessian Ministry of Economy also furthers the market preparation of new, innovative technologies and processes, e.g. through project funding, which allow a significant increase in efficiency of energy conversion plants. A multitude of individual projects and networks unites different actors from politics, economy and research.

Activities to initiate projects, concentrate different interest groups and measures for qualification and information contribute much to the creation and preservation of work places. Information on the different fields, such as energy efficiency, renewable energies, funding projects in the energy sector and energy law are to be found on the website of the Ministry of Economy under www.energieland.hessen.de.

HESSEN



Hessisches Ministerium
für Wirtschaft, Verkehr und
Landesentwicklung

CONTACT

www.energieland.hessen.de

- Hessisches Ministerium für Wirtschaft, Verkehr und Landesentwicklung
Energy Efficiency Division
Head of Division Gabriele Purper
Kaiser-Friedrich-Ring 75
D-65185 Wiesbaden, Germany
Phone +49 (0)611 815-2604, Fax -492604
gabriele.purper@hmwvl.hessen.de

NanoNetzwerkHessen

In March 2004, the NanoNetzwerkHessen, supported by the Hessian Federal State Government, was established by Hessen's five universities and the five academies of applied sciences, to start a close innovation-oriented cooperation in the field of nanosciences based on a cooperation agreement. The initiative NNH is targeted at the concentration of existing competences at Hessian universities, the initiation of cooperations and the further development of Hessen as nanotechnology-location. The NanoNetzwerkHessen is coordinated by the University of Kassel. Researchers from the disciplines of physics, chemistry, biology, pharmaceuticals, medicine, material sciences and the different subjects of engineering sciences or even humanities are working at Hessian universities in fields of nanosciences. This penetration of classic disciplines, in particular, considerably enhances the innovation potential of this science and provides Hessen with excellent starting conditions for cooperations.

Technologies nowadays represented at universities are diversified and range from nanoscale and nanostructured materials, nanosystem technology over nanomedicine, nanomaterial chemistry, nanobiology to nanoanalytics. The work on research and development tasks in these fields, already at a precompetitive stage, together with scientists, developers and users, and thus the bringing together of actors, resources and activities, not only allows the network partners to develop complementary resources, but more than ever connects science to economic application, which contributes to the quicker implementation of nanotechnological knowledge in products, production processes and services.



NANO NETZWERK HESSEN

CONTACT

www.nanonetzwerkessen.de

- Dr. Beatrix Kohnke
(Head of Branch Office)
Mönchebergstrasse 19
D-34109 Kassel, Germany
Phone +49 (0)561 804-2219, Fax -2226
management@nanonetzwerkessen.de

TechnologieTransferNetzwerk Hessen

Since 2001, Hessian universities and the leading trade associations have united to become the TechnologieTransferNetzwerk Hessen (TTN-Hessen), to link the offer of support of knowledge with technology transfers and to facilitate the access to the scientific and technological potential at universities and research facilities for medium-sized companies. In order to be able to achieve this goal, in particular in the field of nanotechnologies, the TTN-Hessen works in close cooperation with its network-partners as well as with the Aktionsline Hessen-Nanotech. Typical examples for this cooperation are company surveys carried out jointly, and technology-oriented events. The CCI-innovation consulting Hessen in Darmstadt, Gießen, Fulda, Kassel and Offenbach have set up regional information centers for technology transfer. Their task is to actively contact companies and offer support for the access to the application-oriented know-how of the universities.

In addition a joint platform for the marketing of cooperation offers of universities is to be found under www.ttn-hessen.de. Under the patronage of the TTN-Hessen, the Hessian universities have united to the joint Intellectual Property Offensive H-IP-O. Contact partners are the agencies for the utilization of patents GINo, INNOVECTIS and TransMIT. They assist inventors in filing patent applications and utilization contracts even in the field of nanotechnologies. The TTN-Hessen is supported and co-financed by the Hessian Ministry of Economy and Science, the HA Hessen Agentur GmbH (branch office), the association of Hessian CCI and the European Social Fund (ESF).

Hessen

TTN

CONTACT

www.ttn-hessen.de

- HA Hessen Agentur GmbH
Dr. Gerrit Stratmann (Project Coordination)
Abraham-Lincoln-Strasse 38-42
D-65189 Wiesbaden, Germany
Phone +49 (0)611 774-8691, Fax -58691
gerrit.stratmann@hessen-agentur.de
www.hessen-agentur.de

The Hessian CCI

Since the beginning of the 1980s, the Hessian CCI offer a special cost-free service to support enterprises in their innovation efforts: the CCI Innovation Consulting Hessen. In times when changes in technology and markets determine increasingly shorter innovation cycles, the competence center provides, in particular, small and medium-sized enterprises with business-related and practical services. The CCI Innovation Consulting is a neutral information broker, which actively accompanies the networking and cluster formation of technology-oriented companies and research. Apart from direct innovation aid, as for example, individual consulting and publications, the Hessian CCI supports the intensive exchange between representatives of economy, science and politics through technology and industry-oriented events. Since 2004, a special focus has been set on nanotechnologies and their potential for the economy. Thus, together with the regional information centers of the TechnologieTransferNetzwerk Hessen and the Ministry of Economy, a series of events was launched in which the possibilities for application and use of nanotechnologies in different branches of industry are examined more closely. The topics range from "Nanotechnologies in Cars of Tomorrow" and "Nanotechnologies in Medical Engineering" to "Nano-Electronics" and "Nano-Surface Technology".



CONTACT

www.itb-hessen.de

- IHK-Innovationsberatung Hessen
Detlev Osterloh (Head)
Phone +49 (0)69 2197-1219
d.osterloh@frankfurt-main.ihk.de

Head Office Frankfurt:
c/o Industrie- und Handelskammer
Frankfurt am Main
Börsenplatz 4
D-60313 Frankfurt am Main, Germany
Phone +49 (0)69 2197-1427, Fax -1484
itb@frankfurt-main.ihk.de

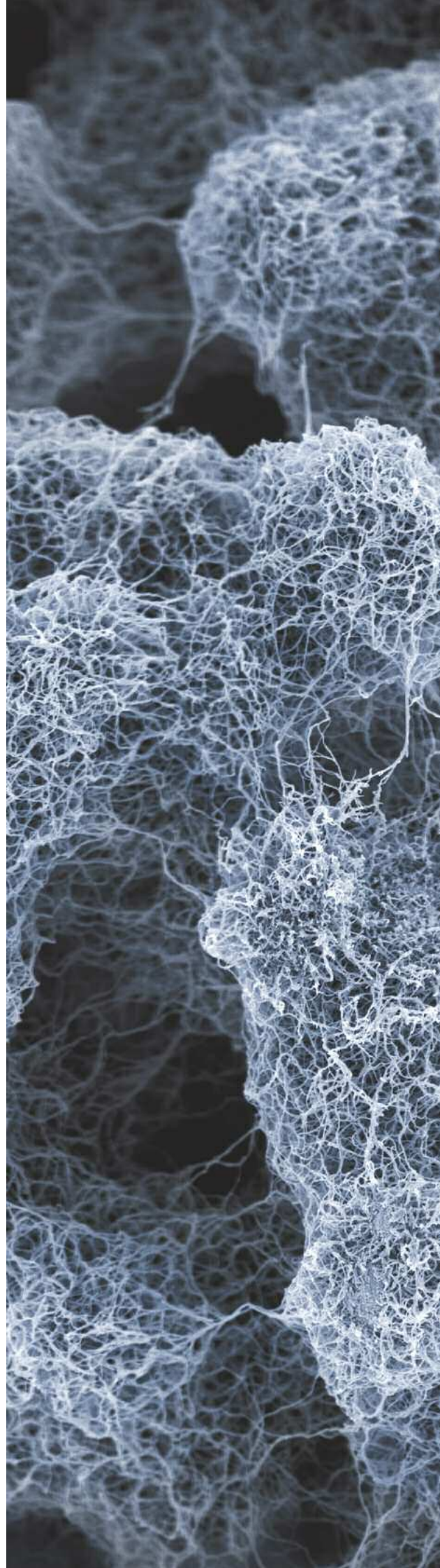

6 Institutions, Associations and Research Associations on the Topic of NanoEnergy

6.1 ISET

Since 1988, the ISET in Kassel and Hanau, with today more than 80 employees, has been dealing with application-oriented research and development for electrical engineering and systems technology for the use of renewable energies. With the latest research results and important technological and scientific guidance in the field of Renewable Energies and energy efficiency, ISET contributes to the future energy politics as the central element of climate politics.

Currently more than 60 % of the global greenhouse gas emissions are attributable to the energy sector. Renewable Energies provide the potential to ensure the total global energy supply. In the short run, energy savings have the highest potential for the reduction of greenhouse gas emissions. Very high efficiency potentials are mainly to be found in the fields of buildings, transport and the processing industry. In a time horizon of already 20 years, wind energy and the energetic use of biomass together with the existing utilization of hydro power could provide two thirds of global electricity. In the longer run (after 2030), above all the direct use of solar energy with its almost unlimited resources will be of decisive importance for meeting the growing energy demand. Apart from the implementation of climate protection aims as well as further sustainability requirements, supply security and maintenance of competitiveness are the most important basic conditions for the further development of the energy sector.

There are versatile technological approaches for the utilization of nanotechnologies. Important fields of application with regard to energy efficiency are energy stores, fuel cells, high-efficiency lighting systems, high-selective catalysts, high-strength, lightweight materials for applications in the transport sector and in the field of heat insulation as well as in renewable energies in solar cells, bioenergy technologies etc.

The applications suggested for the energy sector allow the enhancement of certain properties (e.g. optical, mechanical, electric) of components or systems for the conversion or storage of energy. In addition, enhanced material properties can result in material and energy savings in the production process.

Qualitative and quantitative assessments of the cost reduction potential of nanotechnologies in the energy sector are still not available. Aspects regarding environmental effects on humans and nature have to be considered for the evaluation of the sustainability of new energy technologies.

Nanotechnologies, however, have the unique potential to become an innovation driver for climate protection and energy efficiency. In June 2007, the Aktionslinie Hessen-Nanotech, in cooperation with the ISET, organized the kick-off event NanoEnergy. In lectures and workshops, innovative nano and material technologies for the solution of current challenges in the energy sector were presented and discussed (cf. p. 82).



CONTACT

www.iset.uni-kassel.de

- Institut für Solare Energieversorgungstechnik (ISET) e.V.
Prof. Dr. Jürgen Schmid
Königstor 59, D-34119 Kassel, Germany
Phone +49 (0)561 7294-345, Fax -300
jschmid@iset.uni-kassel.de

6.2 Hydrogen and Fuel Cell Initiative Hessen

As one of the leading networks in this field, the Hydrogen and Fuel Cell Initiative Hessen (H₂BZ-Initiative) is a member of the competence networks Germany. The H₂BZ-Initiative was established when industry, the State of Hessen and the universities had recognized the great innovation and economic-political potential of "hydrogen" as an energy source and the "fuel cell" as an energy converter. The main goal of the H₂BZ-Initiative is to support their members in research, development and demonstration projects, to further the development of competences and to organize technical exchange as well as the mutual information and technology transfer. The H₂BZ-Initiative

provides a network of experts in hydrogen and fuel cell technology which, apart from the already mentioned networking of relevant Hessian actors, are active in location and technology marketing for the State of Hessen. Hessen disposes of an excellent entrepreneurial infrastructure with companies like Umicore, Infracore, BASF, Schunk or Linde and universities, like the Academy of Applied Sciences of Wiesbaden, with outstanding competences in the field of hydrogen and fuel cell technology. The H₂BZ-Initiative regards nanotechnology as a typical interdisciplinary technology, which was not only able to reveal spectacular phenomena from physical, chemical and biological approaches, but which opens up numerous possibilities for fuel cells and hydrogen technology, e. g. in the field of porous resp. catalytic materials or solid-storage materials such as metal hydrides. Such crystalline powders have a huge inner surface and are able to bind enormous amounts of hydrogen in small volumes - and discharge them again - thus smoothing out one of the problems in hydrogen storage.

But also in the sector of intelligent functional materials, nanotechnology has a number of things to offer: Porous nanostructures can be used in fuel cell membranes and electrodes; large surfaces, strictly speaking surface-volume ratios enhance the behavior of gas distribution layers; thin membranes could retain disturbing gases consisting of larger molecules.

Nanotechnology is expected to pave the way for further milestones with regard to a more sustainable energy use and production, and also improves the conditions for a broad market launch of hydrogen and fuel cell technologies. Viewed in this light, it is the H₂BZ-Initiative's task to concentrate, apart from other topics, on energy converting or energy storage-related nanotechnology processes or materials. Therefore, the H₂BZ-Initiative cultivates cooperations between its members and nanotechnology experts like the Nano-Netzwerk Hessen.

The H₂BZ-Initiative explicitly appreciates that the Hessian Ministry of Economy links the strategically important technology fields of Nano and Energy through regular events and publications, like this brochure.

Further information under www.h2bz-hessen.de.



Initiative
Hessen

CONTACT

www.h2bz-hessen.de

- Wasserstoff- und Brennstoffzellen-Initiative Hessen
Dipl.-Ing. Alfred J. Stein (Managing Director)
Abraham-Lincoln-Strasse 38-42
D-65189 Wiesbaden, Germany
Phone +49 (0)611 774-8648
alfred.stein@h2bz-hessen.de

6.3 VCI - Chemistry in the 21st Century: Energy Research and Nanomaterials

The VCI (Association of the German Chemical Industry) (www.vci.de) represents the politico-economic interests of 1,600 German chemical companies and German subsidiaries of foreign enterprises in contacts with politics, public authorities, other fields of industry, the world of science and media. The VCI stands for over 90 percent of the entire German chemical industry. In 2006, this branch of industry realized sales revenues of approx. 162 billion Euros and employs a staff of more than 436,000. VCI is domiciled in Frankfurt/Main and provides eight regional associations. In addition, numerous member companies are organized in altogether 30 sector groups and sector associations, which are corporate members of VCI.

The development of new energy sources and the partial reorganization of our energy system from fossil sources to a new basis is one of the greatest challenges of the 21st century, if not even the greatest. It is to be expected that our future energy supply will be even "more chemical" and without chemistry, the adaptation of our energy system to future challenges will be impossible. Chemistry will be the solution for the challenge to go into the tiniest structures, the nanocosmos, which would remain concealed without modern microscopes. Nanotechnology is already an important tool in chemistry and in the disciplines of materials technology, optics, electronics, biosciences and medicine, where nanomaterials are applied.

Nanomaterials also play an increasingly important role in energy production, energy conversion and energy storage. As catalysts in industry, nanomaterials help produce approx. 80% of all chemical products with reduced consumption of raw materials and energy. Nanomaterials have become a "sine qua non" for the production of integrated circuits, for more precise and smaller structures or for the manufacturing of lithography lenses in the electronic industry. Thin layers of only a few nanometers have been used for data storage in our computers and electronic devices (hard disks and reading heads) for a long time. Without nanomaterials, the manufacturing of wafers and thus of today's computers, laptops, cameras, mobile phones and I-pods is unimaginable.

Solar cells are an environmentally friendly and elegant alternative or supplement to energy production from fossil fuels. For this reason, research activities regarding new material developments are of great energy-strategic importance in this field. Energy efficient solar cells with increased lifetime are only possible through nanolayers. Thus the future design of solar cells will be based on nanometer-thin layer systems. The steadily growing demand for high-capacity, mobile energy supply systems will require batteries with enhanced performance.

Apart from the typical field of application for mobile electronic equipment, powerful energy storage systems are an essential precondition for the widespread implementation of decentralized energy converters (photovoltaics, wind-power turbines), but also in the transport sector (electro-hybrid vehicles).

On the "surface" of future electronics, flexible displays of liquid crystals (LED) and organic polymers will increasingly enhance the efficiency and the application field of flexible solar cells. OLED (Organic Light-Emitting Diodes) are nanolayers - flat, thin, luminescent components of organic semiconducting materials. Apart from their improved performance, their energy consumption is a great advantage compared to conventional technologies. This applies also to new lighting systems, such as light tiles as transparent light sources or torch lights in bank card format.

With its numerous chemistry locations, Hessen will make an important contribution to the development of nanotechnologies, especially in the application field of energy engineering. Already today, Hessian enterprises belong to the world's leading companies in research of functional nanocoatings. The strong network of economy and excellent scientific facilities in the immediate vicinity lays the foundation for the "Innovation Drive Chemistry" in Hessen. Thus the VCI appreciates the initiative of the Hessian Federal State Government for the support of nanotechnology in Hessen. Here, the development of regional networks has to be emphasized, which bridge the gaps between university science, enterprises and research institutes. From the VCI's point of view, such activities contribute decisively to the enhancement of the efficiency of both basic research at universities and independent research facilities in the field of chemistry and of the chemical industrial enterprises in Hessen in the international competition.



CONTACT
www.vci.de

- VERBAND DER CHEMISCHEN INDUSTRIE e.V.
Wissenschaft, Technik und Umwelt
Bereich Wissenschaft und Forschung
Dr. Martin Reuter
Mainzer Landstrasse 55
D-60329 Frankfurt, Germany
Phone +49 (0)69 2556-1584, Fax-1620
reuter@vci.de

6.4 Dechema - Nanotechnology for Sustainable Energy Supply

The DECHEMA is a non-profit scientific and technical society for chemical engineering and biotechnology located in Frankfurt/Main. With its expert panels and events, it provides more than 5000 members as well as the community of experts from industry and universities with the possibility to get informed on the latest novelties of research and science. The Process-Net expert group 'Nanotechnology' is a group with currently 500 members dedicated to the support of nanotechnology through networking and junior staff development. Against the background that raw material reserves become scarcer and in view of the probable climate change, the ensuring of a reliable and environmentally compatible energy supply will become a central issue in the next decades.

Besides energy conversion from renewable energies like solar energy or wind and water power, the more efficient conversion from fossil fuels (oil, gas, coal) will (transitionally) have to be in the focus of the research and development work of all parties involved (institutes and industry). Furthermore, significant energy savings and new efficient methods of energy storage to reduce CO₂-emissions, one of the most important causes for the climate change, will be in the center of the efforts. On the one hand, improved materials like nanocomposites on the basis of carbon nanotubes may enable the manufacturing of bigger and more rugged rotors to increase the efficiency of wind power plants, when wind power is converted into electricity. On the other hand, new nanocomposites provide weight savings and thus energy savings in lightweight construction in the field of automotive engineering and aircraft construction. Furthermore, optimized nanocomposites exhibit the potential for energy and resource saving processes in manufacturing or processing.

Nanostructures in fuel cells and in photovoltaics (organic, hybrid systems, thin-layer technology) could contribute to a sustainable energy supply from renewable energy sources, while minimizing CO₂-emissions. Nanostructures with high yield could also be used for light generation, as for example in Organic Light Emitting Diodes (OLEDs), i.e. for efficient energy conversion, and thus enable new concepts e.g. wide area lighting. Conductive nano-objects as well as the application of new methods of printed electronics, allow the manufacturing of economic and resource-saving circuits (e.g. RFID), which

furthermore provide energy-efficient functions. Optimized nanostructured insulation materials, like nanofoams, with pore sizes and pore wall thicknesses in the nano-range, enable more efficient insulation of buildings and a reduction of the energy consumption. Nanomaterials in electric energy stores, such as the coming generations of the lithium-ion batteries, will help store large energy amounts in a minimum of space losing hardly any energy even after longer storage times. Moreover, nanostructured materials (metal hybrids, metal-organic frameworks) could be utilized for non-electric energy storage, e.g. of hydrogen. Suitable nanostructured catalysts generally support process optimization and thus the reduction of energy consumption in production processes due to their high efficient specific surfaces.

Future customized high-efficient nanoscale catalysts could furthermore help reduce CO₂-emissions, if CO₂ itself is applied as a component in the chemical synthesis of new materials and can therefore no longer contribute to the greenhouse effect.

The expert group Nanotechnology supports the association in all these projects and contributes to the responsible use of nanotechnology. The participation of interested experts is welcome!



CONTACT

www.dechema.de

- DECHEMA
Dr. Peter Krüger, Chief Executive Officer
of ProcessNet Nanotechnology Division
c/o DECHEMA e.V.
Theodor-Heuss-Allee 25
D-60486 Frankfurt am Main, Germany

6.5 Federal Association Solar Economy

Nanotechnologies for the Optimization of Solar Energy Conversion in Photovoltaics

Thinner, more efficient, cheaper: Technologies for solar energy production made sharp progress in the last years. Innovative production systems and the application of new materials increase the efficiency of solar plants and contribute to the continuous reduction of production costs. Solar plants are produced for the application in the mass market, and the solar economy continuous to expand. The European umbrella association of the photovoltaic industry, EPIA, expects a doubling of the world market within the next three years and a world market of 5.6 gigawatts in 2010.

The application fields of nanotechnologies in the solar industry are more and more in the focus of interest: e.g. for nanotexturing of cells for the reduction of reflections or for organic solar cells. However, according to experts, basic knowledge of the variety of application possibilities of nanotechnology research for renewable energy technologies is still lacking. Dye solar cells and polymer solar cells imitating the natural photosynthesis of plants are still in a research phase.

Research is carried out for the production of thin, homogenous layers which, with about 100 nanometers, are approx. three hundred times thinner than a human hair. Organic solar cells enable the further expansion of the application range of solar energy production. While the classic silicon cells are rather used like a high-performance stationary PC, organic photovoltaic may be applied, like in the laptop, in mobile and flexible applications.

In 2007, the Federal Ministry of Education and Research (BMBF) launched the support program "Organic Photovoltaics", which is aimed at the acceleration of the introduction of organic photovoltaic technologies up to the broad industrial application through a combination of basic research, application-oriented material research and development as well as the related process engineering.

The BSW-Solar regards the organic photovoltaic as a promising approach contributing to the technological variety of solar energy production. However, it will take some years until it is possible to expand the market offer through an industrial-scale production of organic solar cells. The Federal Association Solar Economy supports the technological further development of photovoltaics.

The BSW-Solar regards the targeted commitment towards more investment security as well as the establishment of suitable market incentive programmes and a cross-party and cross-society consensus in view of the development of solar energy as the central task of the association's work.



CONTACT

www.bsw-solar.de

- Bundesverband Solarwirtschaft e.V.
Energieforum
Stralauer Platz 34, D-10243 Berlin, Germany
Phone +49 (0)30 29777-8835, Fax -8899
harnisch@bsw-solar.de

6.6 Federal Association of Energy and Water Management BDEW

Possible Fields of Application of Nanotechnologies in Power Transmission

Energy supply in general and the power transmission in particular are facing a number of great challenges now and in the next decades. The liberalization of the European energy markets changed the wide-area power flow decisively and resulted in clearly increased stress on the transmission grids. The conversion to increasingly CO₂-poor power generation leads to completely different production foci - e.g. offshore wind energy - and thus to demands on the construction of new supply lines and balance energy, which can hardly be met by today's technology and approval processes. This calls for political and regulatory action, if German power supply shall continue to be the most reliable in Europe. Modern technology can also help solve such problems, in order that new equipment becomes safer, more efficient and - hopefully - even more economic and allows for a better control of the whole system of power generation, transmission grids and devices at the customer's location. Nanotechnology sets in earlier and opens up new future prospects mainly through further enhanced equipment like stores, supply lines, transformers or power electronics. Although it will be rather the equipment manufacturers than the network operators who are mainly interested in this technology, the network operators also observe it with interest - just like other technologies, e.g. in the information and communication technology - since they may help solve these great challenges.

Promising fields of application for nanotechnology in power transmission and distribution are, for example:

- Low-loss power lines through nanomaterials (e.g. power lines on the basis of optimized superconductors or carbon nanotubes)
- Nano-optimized power electronics (inter alia, nanostructured compound semiconductors for application at high voltages or high temperatures)
- Smart Grids (intelligent power grid management, inter alia, through nanobased sensors and power-electronic components)

The BDEW Federal Association of Energy and Water Management is the first joint representation of interests of the industrial branches of electricity, district heat, gas, water and waste water in Germany. The association successfully represents the interests of the member companies in political debates on national and international level. As the voice of the represented branches, the BDEW is the central contact for decision makers in politics, media and administration as well as for economy, science and society.

The association was founded in 2007 through a merger of the associations VDEW, BGW, VDN and VRE, now comprising 1,800 member companies. With 14 billion Euros annually, these companies together are the biggest investor in German industry. The whole value added chain - from generation and production to distribution and sales - is represented by the BDEW. The spectrum of member companies ranges from local and communal companies to regional and national suppliers.

bdew

Energie. Wasser. Leben.

CONTACT

www.bdew.de

- BDEW Bundesverband der Energie- und Wasserwirtschaft e.V.
Robert-Koch-Platz 4
D-10115 Berlin, Germany
Phone +49 (0)30 726148-100, Fax -200
konstantin.staschus@bdew.de

6.7 Fraunhofer Energy Alliance

21 Fraunhofer Institutes have united to form the Fraunhofer Energy Alliance to provide customers with the competences of the Fraunhofer-Gesellschaft in the energy sector through one single portal. Simpler access to the expertise of the Fraunhofer Institutes is offered, in particular to small and medium-sized companies, but also to politics and the energy business.

The institutes provide the complete range of R&D services, from material research to macroeconomic system analysis with the focus set on the technology development, process engineering and product development. The particular fortes are found in the fields of renewable energies, efficiency technologies, building and components, smart energy grids, energy storage technologies, micro-energy systems as well as hydrogen and fuel cell technology. With regard to complex research and development tasks, the institutes work hand in hand to develop innovative and economically attractive solutions for their customers.

This young and versatile discipline of nanotechnology can contribute essentially to the restructuring of our energy supply system towards sustainability, reliability and higher efficiency along the value added chain of the energy sector. Carbon nanotubes, CNT, for example, help maximize the surface of porous media, thus opening up a wide range of energy-relevant applications: the enhancement of electrodes for electric stores or fuel cells significantly increases energy and power densities; organic solar cells can achieve higher efficiencies through self-organizing absorbers, and absorption refrigerating machines convert heat into cold even more efficiently. But also high mechanical strength and electric conductivity of CNT provide the possibility to make existing products like wind power plants more reliable and more powerful.

Nanoscale treatment may render surfaces more resistant to mechanical stress and high temperatures, which can result in higher efficiencies and longer operating times of turbines, motors or thermal absorbers. But also optical properties of components can be precisely adjusted through nanotechnologies, which helps improve solar cells or light emitting diodes (LED), for example. Their efficiency can be literally increased in quantum leaps by so-called quantum dots.

There are already concrete concepts for the realization of the application possibilities of nanotechnologies described in this brochure as well as for a number of other applications. In order to exploit the whole potential of nanotechnologies research efforts need to be intensified. The resulting innovative products could contribute to a sustainable, reliable and economical energy supply with higher comfort.



Fraunhofer
Allianz
Energie

CONTACT

www.energie.fraunhofer.de

- Fraunhofer-Allianz Energie
Heidenhofstrasse 2
D-79110 Freiburg, Germany
Phone +49 (0)761 4588-5473, Fax -9473
info@energie.fraunhofer.de

7 Annex

7.1 Selected Companies in Hessen in the Nanoenergy Area

Akzo Nobel High Purity Metalorganics GmbH

Emil-von-Behring-Strasse 76
D-35041 Marburg, Germany
www.akzonobel-hpmo.com

Products: Speciality chemicals for semiconductor coatings

BASF Fuel Cells

Industriepark Höchst, G 864
D-65926 Frankfurt am Main, Germany
Phone +49 (0)69 305-4292, Fax -26600
www.pemeas.com, www.basf.com/fuelcell

Products: High temperature polymer membrane fuel cells

Clariant Produkte GmbH

Industrie Park Hoechst Building G 834
D-65926 Frankfurt am Main, Germany
Phone +49 (0)69 305-13791, Fax -331749
www.nano.zeolite.clariant.com

Products: Nano-zeolites as substrate e. g. for new dye solar cells

Evonik Degussa GmbH

Building 1042/118
Rodenbacher Chaussee 4
D-63457 Hanau-Wolfgang, Germany
Phone +49 (0)6181 59-6375, Fax -2391
www.evonik.com

Products: Separators and systems for lithium ion batteries for electro and hybrid cars as well as stationary energy stores, nanomaterials for photovoltaics

Heraeus Holding GmbH

Heraeusstrasse 12
D-63450 Hanau, Germany
Phone +49 (0)6181 35-5706, Fax -3550
www.heraeus.de

Products: Sputter targets for thin film solar cells and functional layers for heat insulation glazings

Hollingsworth & Vose GmbH & Co. KG

Berleburger Strasse 71
D-35116 Hatzfeld (Eder), Germany
Phone +49 (0)6467 801-0, Fax -4202
www.hollingsworth-vose.com

Products: Nanostructured fibers and separators for batteries

European Advanced Superconductors GmbH & Co. KG

Ehrichstrasse 10
D-63450 Hanau, Germany
Phone +49 (0)6181 4384-4100, Fax -4400
www.advancedsupercon.com

Products: High temperature superconductors based on nanomaterials

MAGNETEC GmbH

Industriestrasse 7
D-63505 Langenselbold, Germany
Phone +49 (0)6184 9202-10, Fax -20
www.magnetec.de

Products: Magnetic nanomaterials for electrical engineering

Merck KgaA

Frankfurter Strasse 250
D-64293 Darmstadt, Germany
Phone +49 (0)6151 72-0, Fax -2000
www.merck.de

Products: Nanoporous materials for hydrogen storage, organic semiconductors for photovoltaics

Merck KGaA OLED Materials

Industrial Park Hoechst, F821
D-65926 Frankfurt, Germany
Phone +49 (0)69 305-13705, Fax -21592
www.merck-oled.de

Products: Organic semiconductors for OLED

Rewitec GmbH

Dr.-Hans-Wilhelmi-Weg 1
D-35633 Lahнау, Germany
Phone +49 (0)6441 44599-0, Fax -25
www.rewitec.com

Products: Nanocoating technology for wear protection of metallic components

Schunk Kohlenstofftechnik GmbH

Rodheimer Strasse 59
D-35452 Heuchelheim, Germany
Phone +49 (0)641 608-1460, Fax -1436
www.schunk-group.com

Products: Nanostructured carbon materials for electrodes in batteries, SiBNC-composites for electrical engineering

SolviCore GmbH & Co. KG

Rodenbacher Chaussee 4
D-63457 Hanau, Germany
Phone +49 (0)6181 59-5432, Fax -4240
Internet: www.solvicore.de

Products: Nanostructured catalysts for fuel cells

SGL Carbon AG

Rheingaustrasse 182
D-65203 Wiesbaden, Germany
Phone +49 (0)8271 83-2458, Fax -2419
www.sglcarbon.de

Products: Nanostructured carbon materials for electrical engineering

Umicore AG & Co. KG

Rodenbacher Chaussee 4
D-63403 Hanau, Germany
Phone +49 (0)6181 59-6627, Fax -76227
www.umicore.de

Products: Electro-/Fuel-processing catalysts (fuel cells, catalysts)

VACUUMSCHMELZE GmbH & Co. KG

Grüner Weg 37
D-63450 Hanau, Germany
Phone +49 (0)6181 38-0, Fax --2645
www.vacuumschmelze.de

Products: Nanostructured magnetic materials e.g. for electrical engineering applications

Viessmann Werke GmbH & Co. KG

Viessmann Strasse 1
D-35107 Allendorf/Eder, Germany
Phone +49 (0)6452 70-3410, Fax -6410
www.viessmann.de

Products: Nanoporous materials for high efficient heaters for buildings

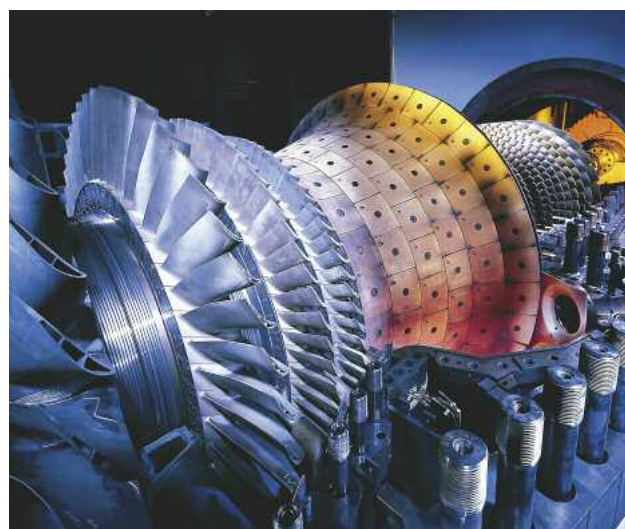

7.2 Selected Research Institutions in Hessen in the Nanoenergy Area

TU Darmstadt

Institute for Nanostructuring and Analytics

Grafenstrasse 2, D-64283 Darmstadt, Germany
Prof. Dr.-Ing. Christina Berger
Dr.-Ing. Alfred Scholz
Phone +49 (0)6151 16-2451, Fax -5659
Mobil +49 (0)178 2846345
scholz@ifw.tu-darmstadt.de
www.tu-darmstadt.de/mpa-ifw

Research topics: Nanocoatings for turbines

Energy Center - Institute of Materials Science

Petersenstrasse 23, D-64287 Darmstadt, Germany
Prof. Dr. Wolfram Jaegermann
Surface Science Division
Phone +49 (0)6151 16-6304, Fax -6308
www.tu-darmstadt.de/fb/ms/fg/ofl/index.tud

Research topics: Thinfilm solar cells, batteries

Department of Material Sciences, Section Renewable Energies

Dr. Christina Roth
Phone +49 (0)6151 16-5498, Fax -6377
c_roth@tu-darmstadt.de
www.tu-darmstadt.de/fb/ms/fg/ee

Research topics: fuel cells, characterization of
nanoscale catalysts

Department of Electrical Engineering, Section Renewable Energies

Prof. Dr.-Ing. Thomas Hartkopf
Phone +49 (0)6151 16-2563, Fax -6074
thomas.hartkopf@re.tu-darmstadt.de
www.ees.tu-darmstadt.de

Research topics: Fuel cells, nanostructured
carbon electrodes, nanoparticles
for catalysts

Fachhochschule Wiesbaden

Division Rüsselsheim

Prof. Dr. Birgit Scheppat
Phone +49 (0)6142 898-512, Fax -528
scheppat@physik.fh-wiesbaden.de
www.physik.fh-wiesbaden.de

Research topics: Fuel cells hydrogen stores

Department Physical Technology, Microsystem Technology, Thin Films

Am Brückweg 26, D-65428 Rüsselsheim, Germany
Prof. Dr. Friedemann Völklein
Phone +49 (0)6142 898-521, Fax -528
voelklein@physik.fh-wiesbaden.de

Research topics: Nanostructured thermoelectrics

Universität Kassel

Institute for Nanostructuring and Analytics

Prof. Dr. H. Hillmer
Phone +49 (0)561 804-4485, Fax -4488
hillmer@ina.uni-kassel.de
www.uni-kassel.de/fb16/te/start.shtml

Research topics: Innovative light guiding systems
Section Renewable Energies

Institute for Solar Energy Technology

Prof. Dr.-Ing. Jürgen Schmid
Phone +49 (0)561-7294-304
jschmid@iset.uni-kassel.de
www.iset.uni-kassel.de

Research topics: Photovoltaics, smart grids,
power electronics, fuel cells

Department of Material Sciences

Univ. Prof. Dr.-Ing. G. Knoll
Mönchebergstrasse 3, D-34125 Kassel, Germany
Phone +49 (0)561 804-2830, Fax -3727
gunter.knoll@imk.uni-kassel.de

Research topics: Tribological nano-coatings,
wear resistant coatings

Justus-Liebig-Universität Gießen

Physical-Chemical Institute

Solid State Physics / Electrochemistry

Prof. Dr. Jürgen Janek

Heinrich-Buff-Ring 58, D-35392 Giessen, Germany

Phone +49 (0)641 99-34500 or -34501, Fax -34509

juergen.janek@phys.chemie.uni-giessen.de

www.chemie.uni-giessen.de/home/janek

Research topics: Nanostructured hydrogen storage

Institute for Applied Physics

Prof. Dr. Derck Schlettwein

Heinrich-Buff-Ring 16, D-35392 Giessen, Germany

Phone +49 (0)641 99-33401, Fax -33409

schlettwein@uni-giessen.de

Research topics: Dye solar cells

Philipps-Universität Marburg

Scientific Centre for Material Sciences

Dr. habil. Wolfgang Stolz

Hans-Meerwein-Strasse

D-35032 Marburg, Germany

Phone +49 (0)641 99-25696, Fax -28935

Wolfgang.Stolz@Physik.Uni-Marburg.de

Research topics: Gas-phase epitaxy for compound semiconductor solar cells

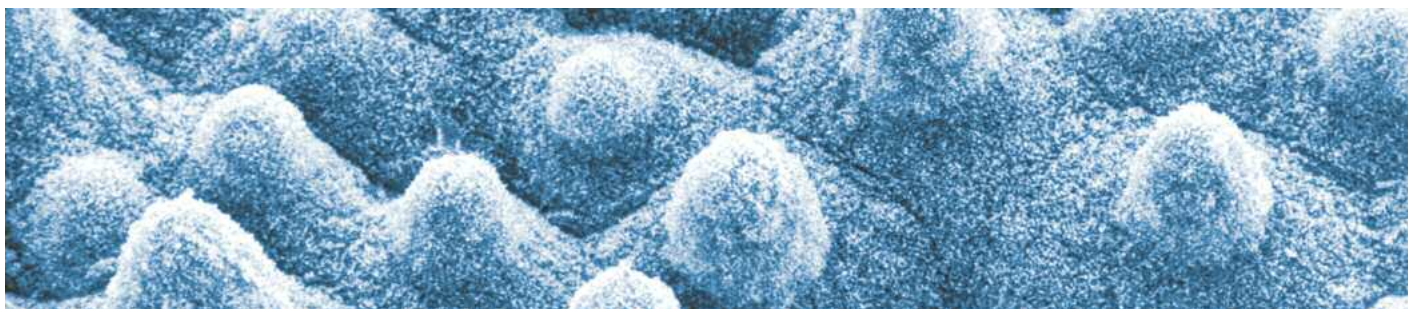

7.3 Further literature

- **Balzer, G. et al.** „Elektrische Energietechnik: Schlüsseltechnologie der Zukunft“, Forschung 2/2007 TU Darmstadt
- **Becker, M., Schneller, T.** „Neue Wege zu Hochtemperaturleitern“, Nachrichten aus der Chemie, 55, December 2007
- **BMWi, BMU** „Bericht zur Umsetzung der in der Kabinettsklausur am 23./24.8.2007 in Meseberg beschlossenen Eckpunkte für ein Integriertes Energie- und Klimaprogramm“, Berlin, 5.12.2007
- **Cientifica** „Nanotechnologies and Energy“, whitepaper, Cientifica, London, 2/2007, www.cientifica.eu
- **CLSA** „Solar Power Sector outlook“, July 2004, www.clsa.com
- **Dechema et al.** „Energieversorgung der Zukunft – der Beitrag der Chemie“, Positionspapier der DECHEMA, DBG, DGMK, GDCh, VDI-GVC, VCI, March 2007
- **EPIA, Greenpeace** „Solar Generation IV – 2007“, Bericht der European Photovoltaics Industry Association und Greenpeace International, 2007
- **European Molecular Biology Organization** „Short-circuiting our fossil fuel habits“, EMBO reports VOL 6, No 3, 2005
- **Forschungsverbund Sonnenenergie** „Themenheft Photovoltaik – Neue Horizonte“ 2003, www.fv-sonnenenergie.de
- **Forschungsverbund Sonnenenergie** „Gemeinsam forschen für die Energie der Zukunft“, Fall 2007
- **GDCh** „Potenziale der Chemie für mehr Energieeffizienz“, Nachrichten aus der GDCh-Energieinitiative, April 2007
- **Lux Research** „Nanotech’s Impact on Energy and Environmental Technologies“, Lux Research 2007, www.luxresearchinc.com
- **Schott** „Solar – Energie für die Zukunft“, Broschüre, Schott AG Mainz, April 2006
- **Schüth, F., Felderhoff, M., Bogdanovic, B.** „Komplexe Hydride als Materialien für die Wasserstoffspeicherung“, Tätigkeitsbericht Max-Planck-Gesellschaft, 2006
- **Sommerlatte, J., Nielsch, K., Böttner, H.** „Thermoelektrische Multitalente“, Physik Journal 6 Nr. 5, Wiley-VCH Verlag, 2007
- **Technology Review** „Energiespeicher“, S. 59-73, August 2007

7.4 Events

- **Impulsveranstaltung Nano Energie** Hanau-Wolfgang, 28.6.2007, www.nanotech-hessen.de/Veranstaltungen/rueckblick/impulsveranstaltung-nano-energie
- **Konferenz Nano Energie – „Nano- und Materialtechnologien für die Energieversorgung der Zukunft“** Hanau-Wolfgang, 11.9.2008, www.hessen-nanotech.de/nanoenergie

Brochure Series

of the Aktionslinie **Hessen-Nanotech** of the Hessian Ministry of Economy, Transport, Urban and Regional Development

Volume 1 Uses of Nanotechnology in Environmental Technology in Hessen

Innovation potentials for companies

Volume 2 NanoMedicine

Innovation potentials in Hessen for medical technology and the pharmaceutical industry

Volume 3 Automotive Nanotechnology

Innovation potentials in Hessen for the automotive industry and its sub-contractors

Volume 4 NanoCommunication

Guide to the communication of chances and risks for small and medium-sized nanotech companies in Hessen

Supplement to the main thread NanoCommunication

Volume 5 NanoOptics

Nanotechnologies for the optical industry - A basis for future innovations in Hessen

Volume 6 NanoProduction

Nanotechnology in the production process as a potential innovation source for companies in Hessen

Volume 7 Uses for Nanotechnologies in Architecture and Civil Engineering

Volume 8 NanoStandardisation

Standardisation in the nanotechnology field as an opportunity for companies in Hessen

Volume 9 Nanotechnology Applications in the Energy Sector

Information / Download / Order:

www.hessen-nanotech.de

Hessen Nanotech

www.hessen-nanotech.de

VDI Technologiezentrum

